



**UM** **Seedbed Tillage**

**COVER CROP SEEDER**

Serial # A71330100 & Higher

FOR ROLLING HARROW 18'-37' UNITS  
Serial #A64740100 & Higher

Part No. 700198

### Foreword



This symbol identifies important safety messages. When you see it, read the message that follows and be alert to the possibility of personal injury.

Remember, safety instructions stated in this manual are for your protection. Read them carefully and follow them closely when working around or using this machine.

Read and study this manual completely before attempting to operate this implement. Take this manual to the field for handy reference when operating, adjusting, or servicing your machine.

When referenced, “Right-Hand” (RH) and “Left-Hand” (LH) side of the machine are determined by standing behind the machine and facing in the direction of travel.

## Product Information

When ordering parts or when requesting further information or assistance, always give the following information:

- Machine name
- Serial number

All products manufactured by Unverferth Mfg. Co., Inc. are warranted to be free from material and workmanship defects for one full year from time of consumer delivery. Your local dealer will gladly assist you with any warranty questions.

Please fill out and retain this portion for your records. The serial number plate is located on the inside of the main frame on the left hand side of the machine (FIG. 1).

Purchase Date \_\_\_\_\_ Model \_\_\_\_\_ Serial No. \_\_\_\_\_

Dealer \_\_\_\_\_ City \_\_\_\_\_

Dealer Contact \_\_\_\_\_ Phone \_\_\_\_\_

FIG. 1

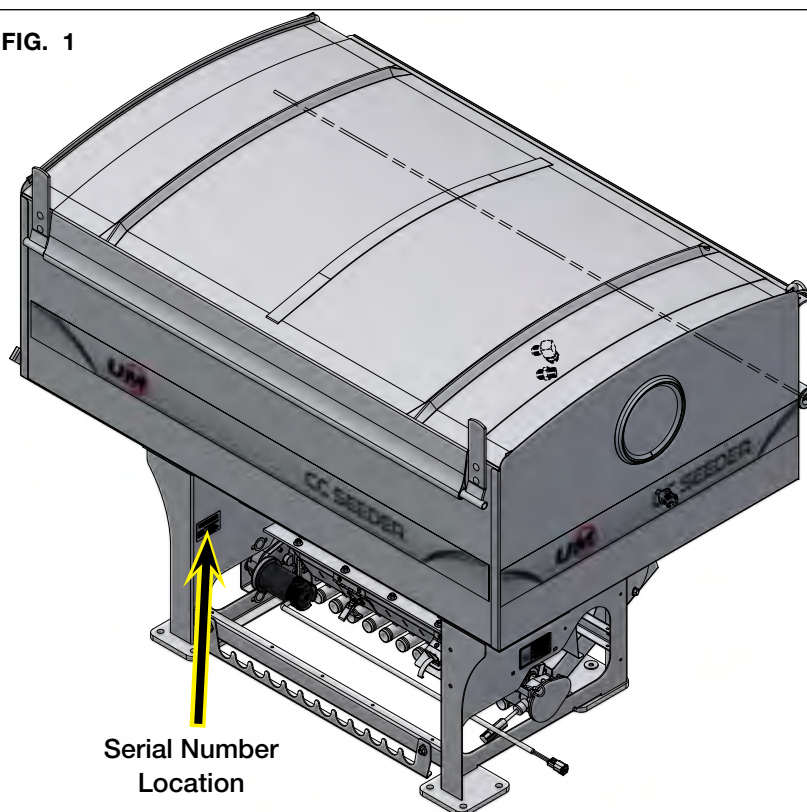

## IMPORTANT

*The information, specifications, and illustrations in the manual are on the basis of information available at the time it was written. Due to continuing improvements in the design and manufacture of Unverferth products, all specifications and information contained herein are subject to change without notice.*

**Table of Contents**

Foreword .....2  
Product Information.....3

**SECTION I  
Safety**

General Hazard Information ..... 1-2  
Safety Decals ..... 1-3  
Following Safety Instructions ..... 1-4  
Before Servicing or Operating ..... 1-4  
During Operation ..... 1-5  
During Transport..... 1-5  
Pressurized Oil ..... 1-6  
Preparing for Emergencies..... 1-7  
Wearing Protective Equipment ..... 1-7

**SECTION II  
Set Up**

Pre-Delivery Checklist ..... 2-2  
General Set up Information ..... 2-2  
Basic Set Up  
    Tank Assembly..... 2-3  
    Hydraulics ..... 2-14  
    Step ..... 2-16  
    Gravity latch Assembly ..... 2-17  
    ISO-BUS Rate Controller - Wiring ..... 2-18  
    Non ISO-BUS Variable Rate Controller - Wiring ..... 2-24  
    Nozzle and Hose Placement and Routing ..... 2-29  
Overhead Layouts..... 2-35  
Raven RCM Guide..... 2-51  
Non ISO-BUS/Variable Rate Controller Guide..... 2-61



**Table of Contents**

**SECTION III**  
**Operation**

General Operation Information ..... 3-2  
Preparing Tractor..... 3-2  
Preparing Cover Crop Seeder..... 3-3  
    Bolts and Nuts ..... 3-3  
    Pins..... 3-3  
    Hydraulics ..... 3-3  
Operating Instructions ..... 3-4  
    Preparing Seed Meter ..... 3-6  
    Raise The Implement ..... 3-6  
Nozzle Seed Rate Chart ..... 3-8  
RAVEN RCM - Catch Test Calibration Procedure ..... 3-13  
Variable Rate - Catch Test Calibration Procedure ..... 3-16

**SECTION IV**  
**Maintenance**

How to Clean Out Seed Meter Assembly ..... 4-2  
How to Clean Out Seed Meter Cups..... 4-6  
How to Replace Seals in Fan Motor ..... 4-8  
Storage..... 4-9  
Electrical Schematics ..... 4-10  
Torque Chart ..... 4-19  
Hydraulic Fittings ..... 4-19

**Table of Contents**

**SECTION V**  
**Parts**

Tank Components.....	5-2
Seed Delivery Components.....	5-4
Seed Meter Assembly Components.....	5-6
Bracket, Nozzle & Mounting Components.....	5-8
Hydraulic Components.....	5-10
Electrical Components - ISO-Bus Rate Controller.....	5-12
Electrical Components - Non ISO-Bus / Variable Rate Controller.....	5-14
Tarp Components.....	5-16
Frame Brace Kit.....	5-18
Rolling Harrow Bolt Kit.....	5-19

# **SECTION I**

# **Safety**

- General Hazard Information ..... 1-2
- Safety Decals ..... 1-3
- Following Safety Instructions ..... 1-4
- Before Servicing or Operating ..... 1-4
- During Operation ..... 1-5
- During Transport..... 1-5
- Pressurized Oil ..... 1-6
- Preparing for Emergencies..... 1-7
- Wearing Protective Equipment ..... 1-7

## General Hazard Information

No accident-prevention program can be successful without the wholehearted cooperation of the person who is directly responsible for the operation of the equipment.

A large number of accidents can be prevented only by the operator anticipating the result before the accident is caused and doing something about it. No power-driven equipment, whether it be transportation or processing, whether it be on the highway, in the field, or in the industrial plant, can be safer than the person who is at the controls. If accidents are to be prevented--and they can be prevented--it will be done by the operators who accept the full measure of their responsibility.

It is true that the designer, the manufacturer, and the safety engineer can help; and they will help, but their combined efforts can be wiped out by a single careless act of the operator.

It is said that, "the best kind of a safety device is a careful operator." We, at Unverferth Mfg. Co., Inc. ask that you be that kind of operator.



**REMEMBER:**  
**THINK SAFETY**  
A CAREFUL OPERATOR IS THE  
BEST INSURANCE AGAINST AN  
ACCIDENT!

### SIGNAL WORDS



INDICATES AN EXTREMELY HAZARDOUS SITUATION OR ACTION THAT WILL RESULT IN SERIOUS INJURY OR DEATH.

---



INDICATES A HAZARDOUS SITUATION OR ACTION THAT COULD RESULT IN SERIOUS INJURY OR DEATH.

---



INDICATES AN UNSAFE SITUATION OR ACTION THAT MAY RESULT IN PERSONAL INJURY.

---



*Is used for instruction on operating, adjusting, or servicing a machine.*

## Safety Decals

### **WARNING**

- REPLACE LOST, DAMAGED, PAINTED, OR UNREADABLE DECALS IMMEDIATELY. IF PARTS THAT HAVE DECALS ARE REPLACED, ALSO MAKE SURE TO INSTALL NEW DECALS. THESE DECALS INFORM AND REMIND THE OPERATOR WITH OPERATIONAL INFORMATION AND SAFETY MESSAGES.

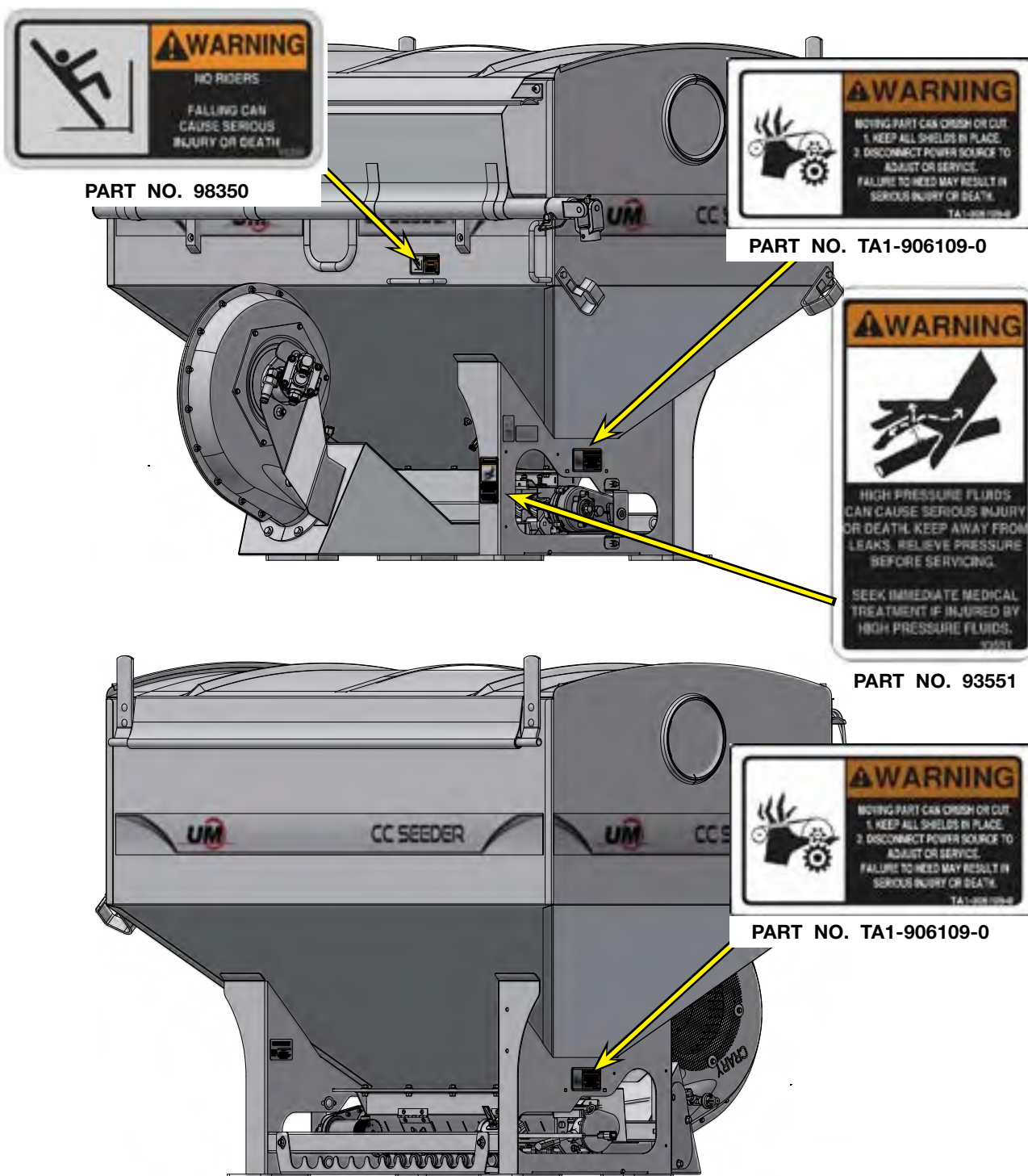

### Following Safety Instructions

- Read and understand this operator's manual before operating.



- All machinery should be operated only by trained and authorized personnel.

- To prevent machine damage, use only attachments and service parts approved by the manufacturer.

- Always shut tractor engine off and remove key before servicing.



- Avoid personal attire such as loose fitting clothing, shoestrings, drawstrings, pants cuffs, long hair, etc., that may become entangled in moving parts.

- Do not allow anyone to ride on the implement. Make sure everyone is clear before operating machine or towing vehicle.



- Never attempt to operate implement unless you are in driver's seat.



### Before Servicing or Operating

- Avoid working under an implement; however, if it becomes absolutely unavoidable, make sure the implement is safely blocked.



- Do not stand between towing vehicle and implement during hitching.

- Always make certain everyone and everything is clear of the machine before beginning operation.

- Verify that all safety shields are in place and properly secured.

- Ensure that all applicable safety decals are installed and legible.

- When working around the implement, be careful not to be cut by sharp edges.

### During Operation

- Regulate speed to field conditions. Maintain complete control at all times.
- Never service or lubricate equipment when in operation.
- Keep away from overhead power lines. Electrical shock can cause serious injury or death. 
- Use extreme care when operating close to ditches, fences, or on hillsides.
- Do not leave towing vehicle unattended with engine running.
- Seed being transported may contain seed treatment. Read and follow all requirements for personal protective equipment and first aid as outlined on seed tags.

### During Transport

- Comply with all laws governing highway safety when moving machinery.
- Use transport lights as required by all laws to adequately warn operators of other vehicles.
- Use good judgment when transporting equipment on highways. Regulate speed to road conditions and maintain complete control.
- Maximum transport speed of this implement should never exceed 20 mph as indicated on the machine. Maximum transport speed of any combination of implements must not exceed the lowest specified speed of the implements in combination. Do not exceed 10 mph during off-highway travel.
- Slow down before making sharp turns to avoid tipping. Drive slowly over rough ground and side slopes.
- It is probable that this implement is taller, wider, and longer than the towing vehicle. Become aware of and avoid all obstacles and hazards in the travel path of the equipment, such as power lines, ditches, etc.

### Pressurized Oil

- Relieve the hydraulic system of all pressure before adjusting or servicing. See hydraulic power unit manual for procedure to relieve pressure.
- High-pressure fluids can penetrate the skin and cause serious injury or death. Leaks of high-pressure fluids may not be visible. Use cardboard or wood to detect leaks in the hydraulic system. Seek medical treatment immediately if injured by high-pressure fluids. 
- Hydraulic system must be purged of air before operating to prevent serious injury or death.
- Do not bend or strike high-pressure lines. Do not install bent or damaged tubes or hoses.
- Repair all oil leaks. Leaks can cause fires, personal injury, and environmental damage.
- Route hoses and lines carefully to prevent premature failure due to kinking and rubbing against other parts. Make sure that all clamps, guards and shields are installed correctly.
- Check hydraulic hoses and tubes carefully. Replace components as necessary if any of the following conditions are found:
  - End fittings damaged, displaced, or leaking.
  - Outer covering chafed/cut or wire reinforcing exposed.
  - Outer covering ballooning locally.
  - Evidence of kinking or crushing of the flexible part of a hose.



## Preparing for Emergencies

- Keep a first aid kit and properly rated fire extinguisher nearby.



- Keep emergency numbers for fire, rescue, and poison control personnel near the phone.



## Wearing Protective Equipment

- Wear clothing and personal protective equipment appropriate for the job.



- Wear steel-toed shoes when operating.



- Wear hearing protection when exposed to loud noises.



- Do not wear additional hearing impairing devices such as radio headphones, etc



**Notes**

## SECTION II

# Set Up

Pre-Delivery Checklist.....	2-2
General Set up Information .....	2-2
Basic Set Up	
Tank Assembly.....	2-3
Hydraulics .....	2-14
Step .....	2-16
Gravity latch Assembly.....	2-17
ISO-BUS Rate Controller - Wiring .....	2-18
Non ISO-BUS Variable Rate Controller - Wiring .....	2-24
Nozzle and Hose Placement and Routing .....	2-29
Overhead Layouts.....	2-35
Raven RCM Guide.....	2-51
Non ISO-BUS/Variable Rate Controller Guide.....	2-61

### Pre-Delivery Checklist

After the Seed Pro tender has been completely assembled, use the following checklist and inspect the seed tender. Check off each item as it is found satisfactory or after proper adjustment is made.

- Torque all mounting hardware as specified by torque chart.
- All hoses and wires are secured.
- All doors and shields are in place.
- Check to be sure all safety decals are correctly located and legible. Replace if damaged.
- Paint all parts scratched in shipment.

### General Set Up Information

For your safety, and the safety of others, use proper tools and equipment and always use safe working procedures. Refer to these instructions before starting any work on your machine.

#### **IMPORTANT**

- *The procedures for assembling this unit were intended for two or more people.*

For ease of assembly, install all hardware loosely until assembly is complete and then tighten according to “Torque Chart” unless otherwise specified.

#### **⚠ WARNING**

- **READ AND UNDERSTAND SAFETY RULES BEFORE OPERATING OR SERVICING THIS MACHINE. REVIEW "SAFETY" SECTION IN THIS MANUAL IF NECESSARY.**
- **TIPPING OR MOVEMENT OF THE MACHINE CAN CAUSE SERIOUS INJURY OR DEATH. BE SURE THE MACHINE IS SECURELY BLOCKED.**
- **MOVING PARTS CAN CRUSH AND CUT. KEEP AWAY FROM MOVING PARTS.**
- **KEEP HANDS CLEAR OF PINCH POINT AREAS.**
- **FALLING OBJECTS CAN CAUSE SERIOUS INJURY OR DEATH. DO NOT WORK UNDER THE MACHINE AT ANY TIME WHILE BEING HOISTED. BE SURE ALL LIFTING DEVICES AND SUPPORTS ARE RATED FOR THE LOADS BEING HOISTED. THESE ASSEMBLY INSTRUCTIONS WILL REQUIRE SAFE LIFTING DEVICES UP TO 1,000 LBS. SPECIFIC LOAD RATINGS FOR INDIVIDUAL LOADS WILL BE GIVEN AT THE APPROPRIATE TIME IN THE INSTRUCTIONS.**
- **EYE PROTECTION AND OTHER APPROPRIATE PERSONAL PROTECTIVE EQUIPMENT MUST BE WORN WHILE SERVICING THE IMPLEMENT.**

## Basic Set Up

### **WARNING**

- HIGH-PRESSURE FLUIDS CAN PENETRATE THE SKIN AND CAUSE SERIOUS INJURY OR DEATH. LEAKS OF HIGH-PRESSURE FLUIDS MAY NOT BE VISIBLE. USE CARDBOARD OR WOOD TO DETECT LEAKS IN THE HYDRAULIC SYSTEM. SEEK MEDICAL TREATMENT IMMEDIATELY IF INJURED BY HIGH-PRESSURE FLUIDS.
- RELIEVE THE HYDRAULIC SYSTEM OF ALL PRESSURE BEFORE ADJUSTING OR SERVICING. SEE THE HYDRAULIC POWER UNIT OPERATOR'S MANUAL FOR PROPER PROCEDURES.
- HYDRAULIC SYSTEM MUST BE PURGED OF AIR BEFORE OPERATING TO PREVENT SERIOUS INJURY OR DEATH.



## Tank Assembly

1. Open roll tarp.
2. Remove and save the center tarp bow by removing the nut and capscrew.
3. Remove the bundles, OSB panel, cardboard sheet, foot switch, hydraulic hoses, and air hose from inside the tank.
4. Reinstall tarp bow with hardware removed in step 2.
5. Remove the hardware securing the tank assembly to the shipping pallet.

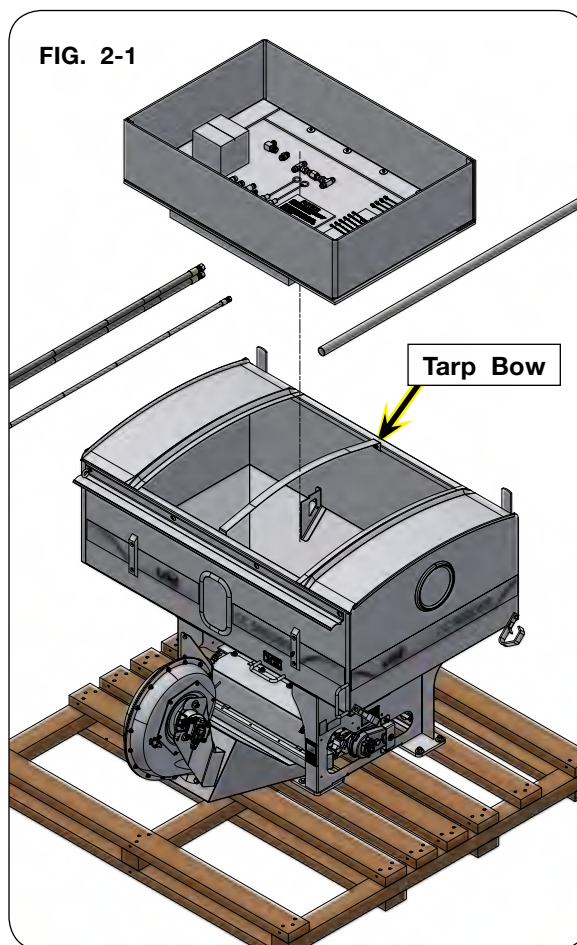

## Basic Set Up

### Tank Assembly (continued)

6. Park the unit on a firm, level surface. Unfold the wings into the field working position, and lower the machine onto the ground. Block the wheels on the machine to keep it from moving. Remove all hydraulic pressure on the implement. See your tractor's operators manual for the proper procedure. Set the vehicle parking brake, shut off the engine and remove the ignition key.



**NOTE:** ROLLING HARROW MODELS with SERIAL NUMBER A58720200 – A64740099, must have the reinforcing kit 78355G (Green) or 78355R (Red) and mounting kit 78390G (Green) or 78390R (Red).

**NOTE:** COVER CROP SEEDER not available for ROLLING HARROWS MODELS with SERIAL NUMBERS PRIOR to A58720200.

7. **ROLLING HARROW MODELS WITH SERIAL NUMBER A64740100 & UP WITH NO TONGUE CENTER SUPPORT**

- A. Loosely attach the front tank stand bracket (77807G or 77807R) and rear tank stand bracket (77811G or 77811R) to the frame with four 1/2"-13UNC x 4 1/16" U-bolts (9502320) and eight 1/2"-13UNC lock nuts (9800). Slide brackets as far forward as possible and parallel to the ROLLING HARROW main frame. Torque hardware. See torque chart for proper tightening of all hardware.

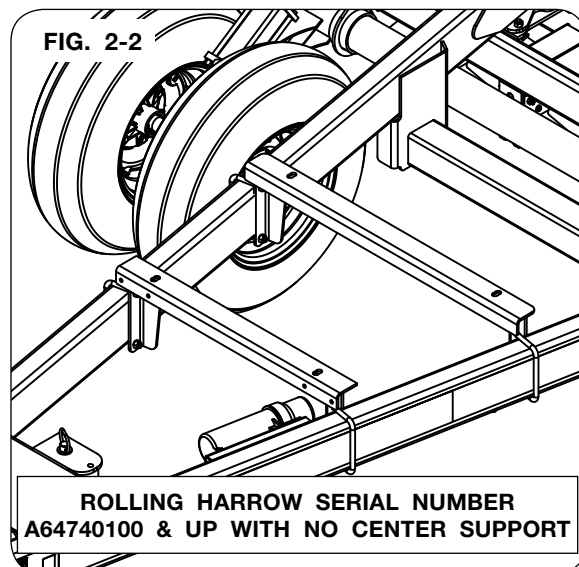

**ROLLING HARROW MODELS WITH SERIAL NUMBER A58720200 & UP WITH TONGUE CENTER SUPPORT**

- A. Loosely attach the front tank stand bracket (77622G or 77622R) to the Rolling Harrow with two 1/2"-13UNC x 4 1/16" U-bolts (9502320) and four 1/2"-13UNC lock nuts (9800). Slide brackets as far forward as possible and parallel to the main frame. Torque hardware. See torque chart for proper tightening of all hardware.

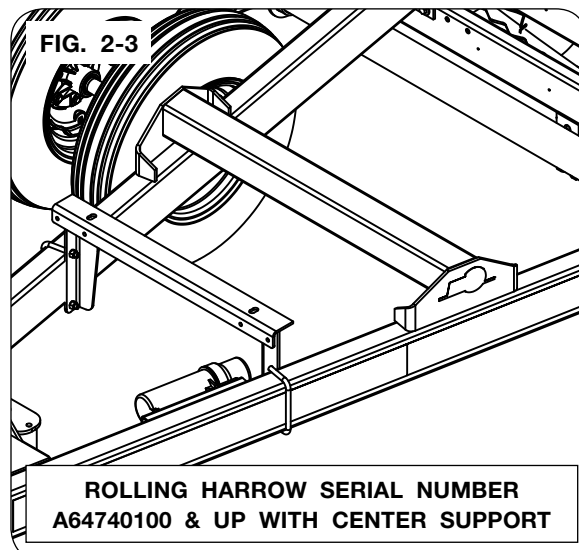

## Basic Set Up

### Tank Assembly (continued)

#### 7. Continued (ROLLING HARROW MODELS WITH SERIAL NUMBER A64740100 & UP)

B. Remove and replace the vertical bolts attaching the A-frame to the mainframe. When replacing with the supplied longer hardware, a washer should be placed on the bottom of the mounting plate. The bolt should be secured with the nut on top. Torque the hardware to 82-88 FT. LBS. Complete this step for all 8 vertical bolts. (FIG. 2-4 & FIG. 2-5)

C. Remove all 3 horizontal bolts from one of the sides connecting the A-frame to the main frame. Discard the hardware. Use 3 supplied longer bolts with plate 78945B on the rear of the mounting plate. Secure using the supplied nuts and torque to 82-88 FT. LBS. Repeat this step for the other side. (FIG. 2-6 & FIG. 2-7)

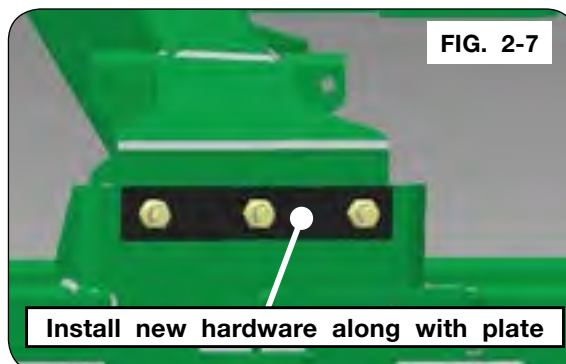
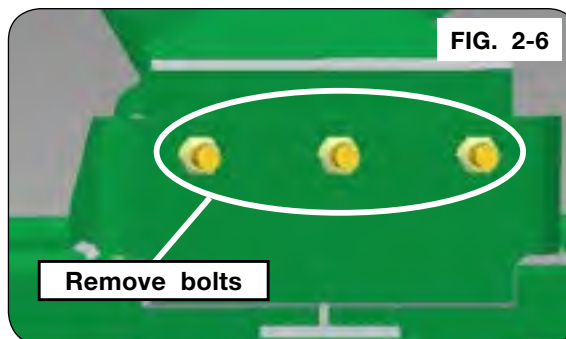
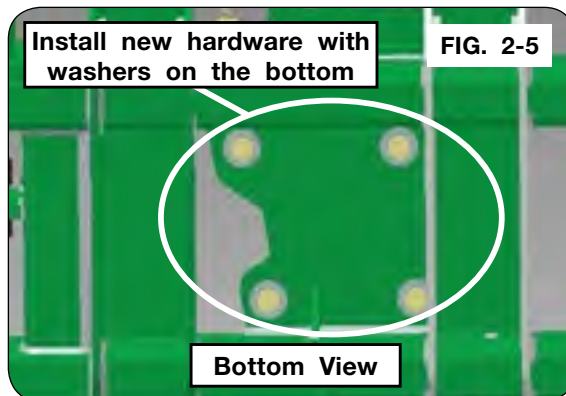
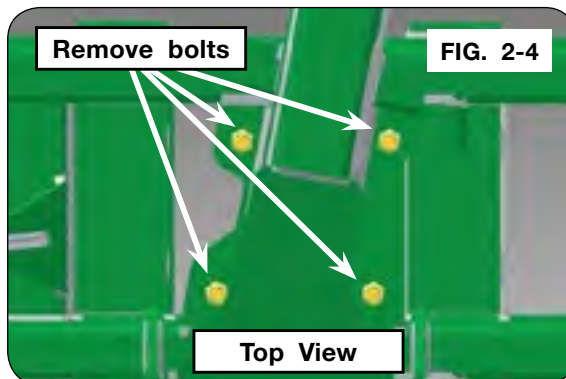



## Basic Set Up

### Tank Assembly (continued)

#### 7. Continued (ROLLING HARROW MODELS WITH SERIAL NUMBER A64740100 & UP)

D. Using a safe lifting device rated for 100 lbs., support the rod end of one of the wing fold cylinders. Remove the roll pin securing the rod end pin of a wing fold cylinder. Remove the cylinder pin and, using the safe lifting device, rotate the cylinder out of the way and secure. Retain the roll pin and cylinder pin.

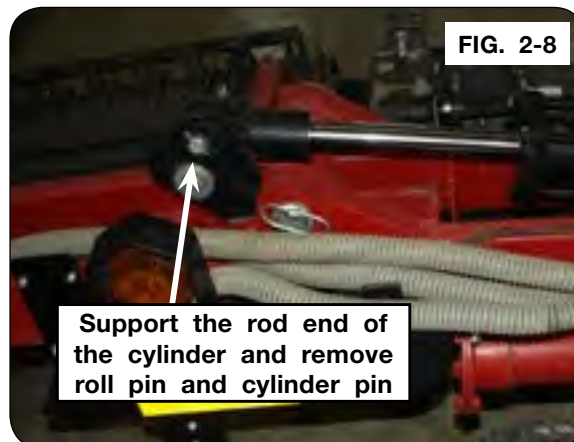

E. Install the frame braces into the main frame behind the main lift lug. The solid plate will be at the rear of the machine. The split plate will be against the rear of the forward frame tube. Torque the hardware evenly to 62-68 ft. lbs.

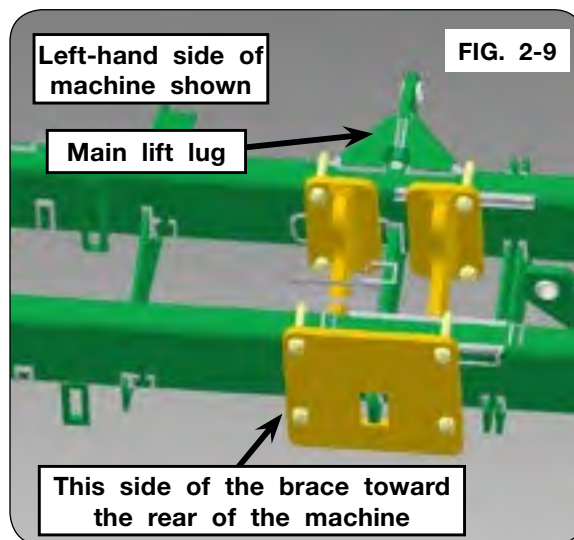

F. Using a safe lifting device rated for 100 lbs., rotate the hydraulic cylinder back into position and insert the cylinder pin. Secure the pin in place using the roll pin removed in step D.



G. Repeat steps D-F for the other side of the machine.



## Basic Set Up

### Tank Assembly (continued)

#### 7. Continued (ROLLING HARROW MODELS WITH SERIAL NUMBER A58720200 – A64740099) Installation of A-Frame Support Kit #78355G or 78355R (Steps A - H)

A. Remove and save the pin and rear stop collar. (FIG. 2-11)

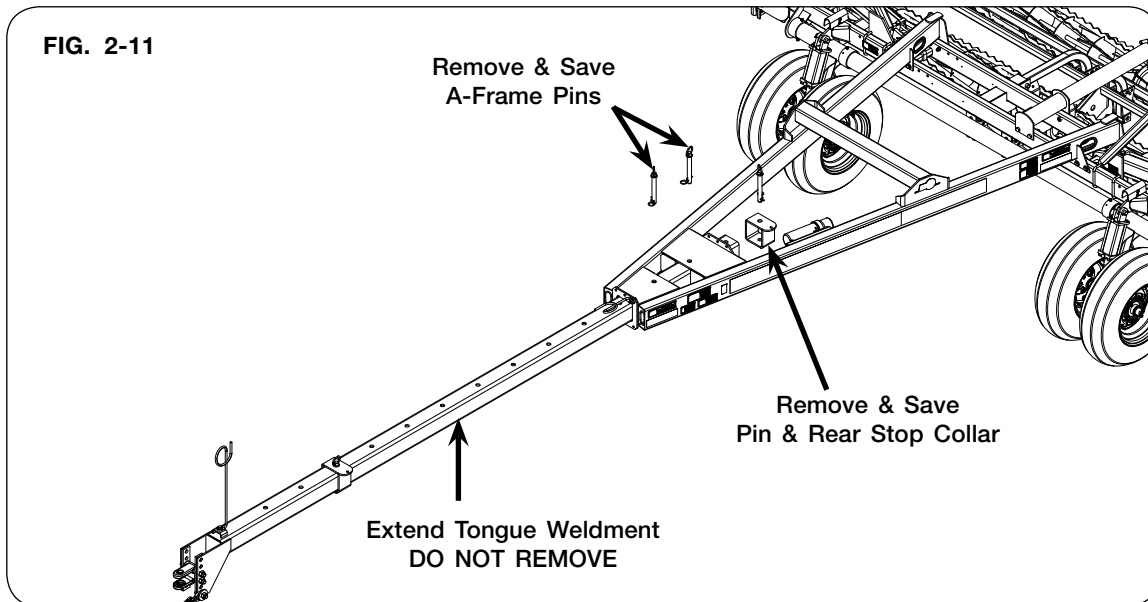

B. Remove and save the A-Frame pins. Extend, but DO NOT REMOVE the tongue weldment.

C. Loosely attach the front mount weldment with six 1/2"-13UNC x 2" capscrews (9390-103), twelve 1/2" SAE flat washers (9405-086), and six 1/2"-13UNC locknuts (9800). (FIG. 2-12)

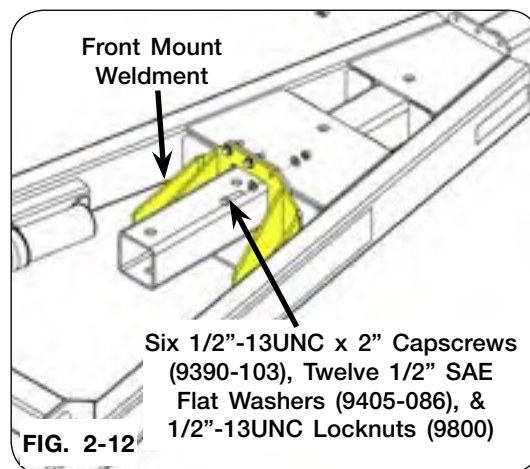

D. Slide the tongue weldment back into transport position. Reattach the pin and rear stop collar. (FIG. 2-13)



## Basic Set Up

### Tank Assembly (continued)

#### 7. Continued (ROLLING HARROW MODELS WITH SERIAL NUMBER A58720200 – A64740099)

- E. Remove and discard the front A-frame hardware. (FIG. 2-14)

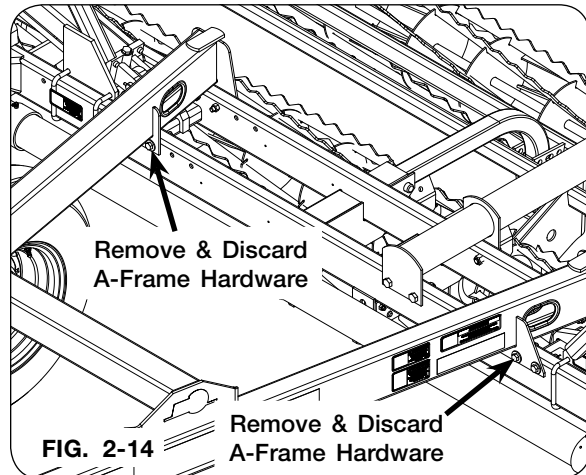

- F. Attach the rear brace weldment to the A-frame with six 1/2"-13UNC x 5 1/2" capscrews (9390-114), 1/2" SAE flat washers (9405-086), and 1/2"-13UNC locknuts (9800). (FIG. 2-15 & FIG. 2-16)

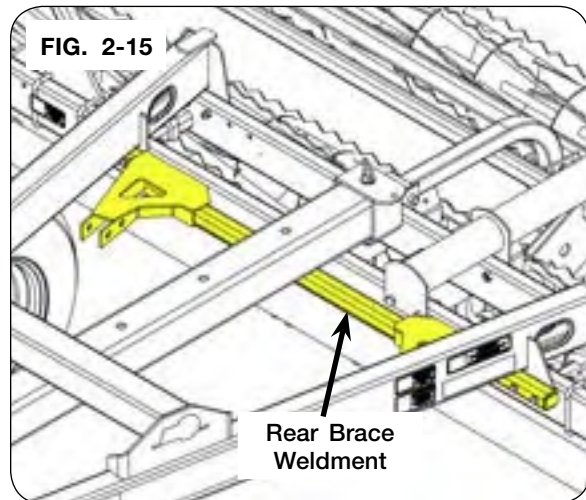

## Basic Set Up

### Tank Assembly (continued)

#### 7. Continued (ROLLING HARROW MODELS WITH SERIAL NUMBER A58720200 – A64740099)

G. Assemble the tubes to the front mount weldment and rear brace weldment with eight 5/8"-11UNC x 4" capscrews (9390-132), sixteen 5/8" SAE flat washers (9405-098) and eight 5/8"-11UNC locknuts (9801).

H. Torque hardware:  
1/2"-13UNC to 62-68 Ft.-Lbs.  
5/8"-11UNC to 120-135 Ft.-Lbs.

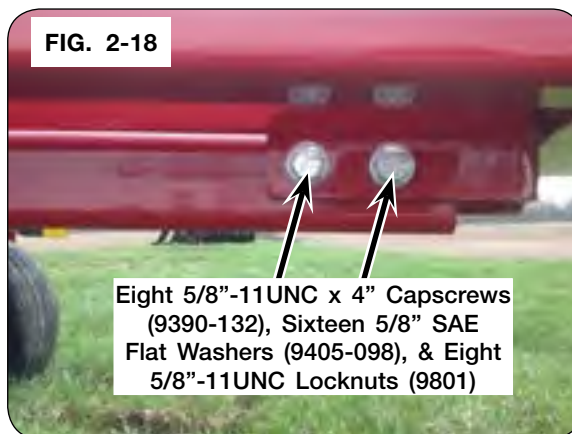

## Basic Set Up

### Tank Assembly (continued)

#### 7. Continued (ROLLING HARROW MODELS WITH SERIAL NUMBER A58720200 – A64740099)

- I. Using a safe lifting device rated for 100 lbs., support the rod end of one of the wing fold cylinders. Remove the roll pin securing the rod end pin of a wing fold cylinder. Remove the cylinder pin and, using the safe lifting device, rotate the cylinder out of the way and secure. Retain the roll pin and cylinder pin.

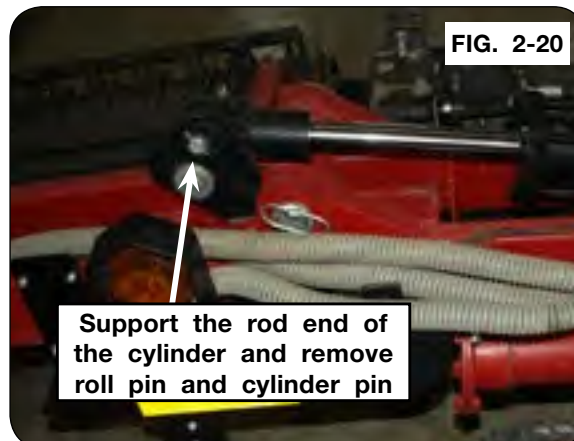

- J. Install the frame braces into the main frame behind the main lift lug. The solid plate will be at the rear of the machine. The split plate will be against the rear of the forward frame tube. Torque the hardware evenly to 62-68 ft. lbs.

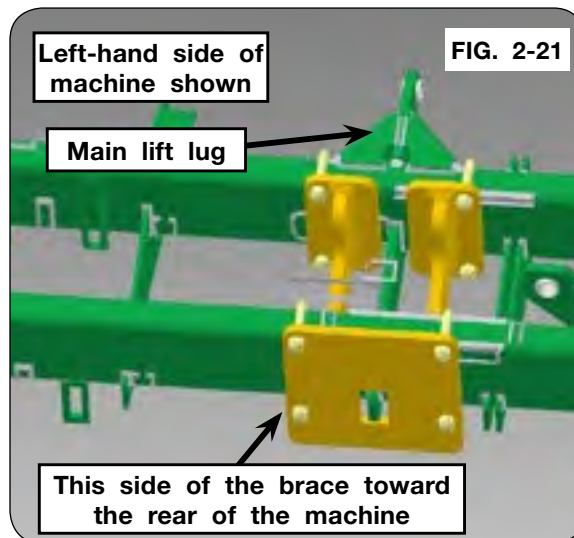

- K. Using a safe lifting device rated for 100 lbs., rotate the hydraulic cylinder back into position and insert the cylinder pin. Secure the pin in place using the roll pin removed in step I.



- L. Repeat steps I-K for the other side of the machine.



## Basic Set Up

### Tank Assembly (continued)

- Using a safe lifting device rated at a minimum of 1,000 lbs. and the 4 loops inside the tank, place the tank on the a-frame.
- ROLLING HARROW MODELS WITH SERIAL NUMBER A58720200 - A64740099 WITH CENTER SUPPORT**

#### Installation of Mounting Kit #78390G or 78390R

Loosely assemble the tank assembly to front tank stand bracket (77622G or 77622R) with two 1/2"-13UNC x 1 1/2" capscrews (9390-101), 1/2" USS flat washers (9405-088), and 1/2"-13UNC lock nuts (9800). (FIG. 2-23)

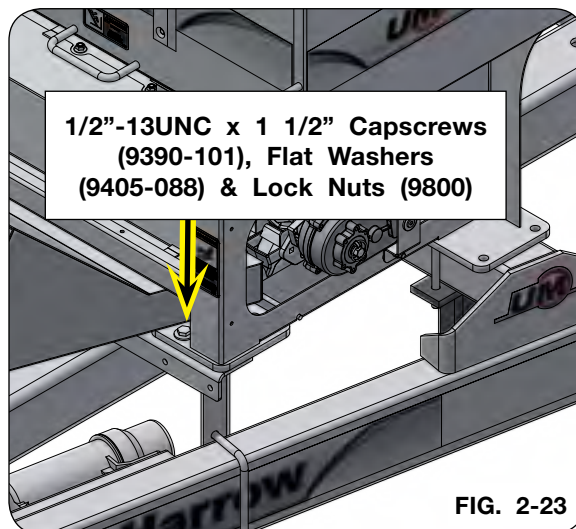

Attach the rear of the tank assembly with support reinforcement weldment (78431G or 78431R), 1/2"-13UNC x 6" capscrews (9390-115), 1/2" USS flat washers (9405-088), and four 1/2"-13UNC lock nuts (9800). (FIG. 2-24)

Torque hardware. See torque chart for proper tightening of all hardware.

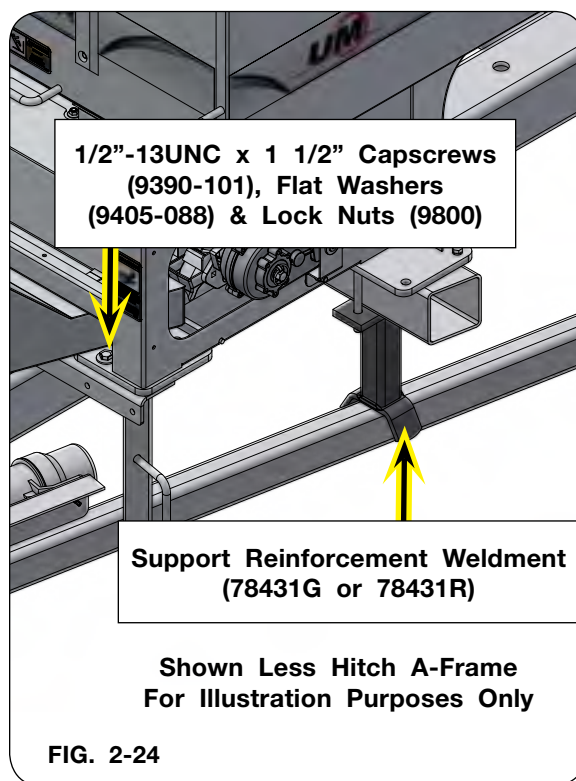

## Basic Set Up

### Tank Assembly (continued)

#### 9. Continued

**ROLLING HARROW MODELS WITH SERIAL NUMBER A58720200 – A64740099 WITH CENTER SUPPORT**

#### Installation of Mounting Kit #78390G or 78390R (continued)

Loosely assemble the brackets (78417B) to the cover crop mounting tubes (78418B) and A-frame support kit tubes (78355G or 78355R) with 1/2"-13UNC U-bolts (91120) and 1/2"-13UNC lock nuts (9800). (FIG. 2-25)

Torque hardware. See torque chart for proper tightening of all hardware.

FIG. 2-25

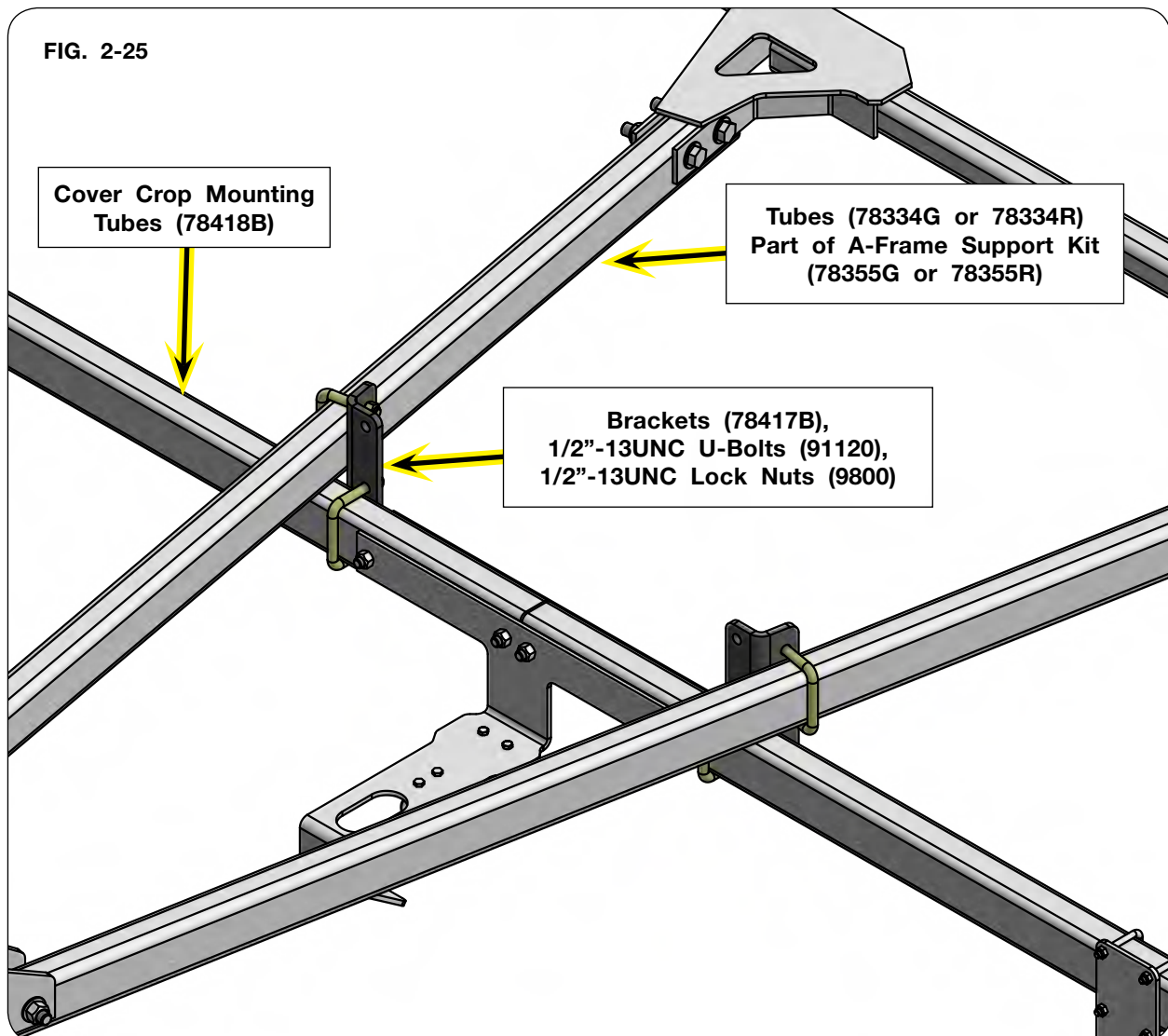

## Basic Set Up

### Tank Assembly (continued)

#### 9. Continued

##### ROLLING HARROW MODELS WITH SERIAL NUMBER A64740100 & UP WITH NO CENTER SUPPORT

Loosely assemble the tank assembly to front tank stand bracket (77807G or 77807R) and rear tank stand bracket (77811G or 77811R) with four 1/2"-13UNC x 1 1/2" capscrows (9390-101), 1/2" USS flat washers (9405-088), and 1/2"-13UNC lock nuts (9800). Torque hardware. See torque chart for proper tightening of all hardware.

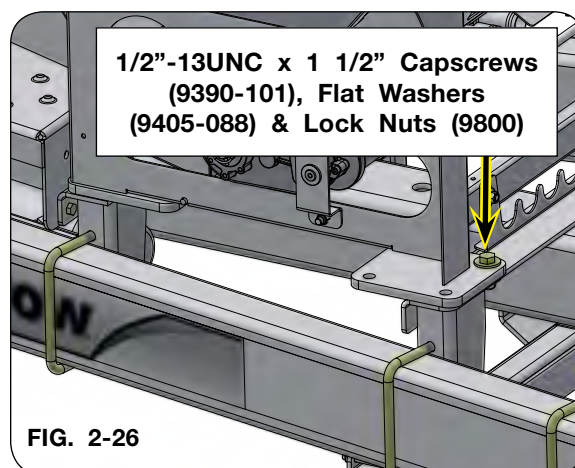

##### ROLLING HARROW MODELS WITH SERIAL NUMBER A64740100 & UP WITH CENTER SUPPORT

Loosely assemble the tank assembly to front tank stand bracket (77807G or 77807R) with two 1/2"-13UNC x 1 1/2" capscrows (9390-101), 1/2" USS flat washers (9405-088), and 1/2"-13UNC lock nuts (9800). Attach the rear with two 1/2"-13UNC x 4 9/16" U-bolts (96568), four 1/2" USS flat washers (9405-088), and four 1/2"-13UNC lock nuts (9800). Torque hardware. See torque chart for proper tightening of all hardware.

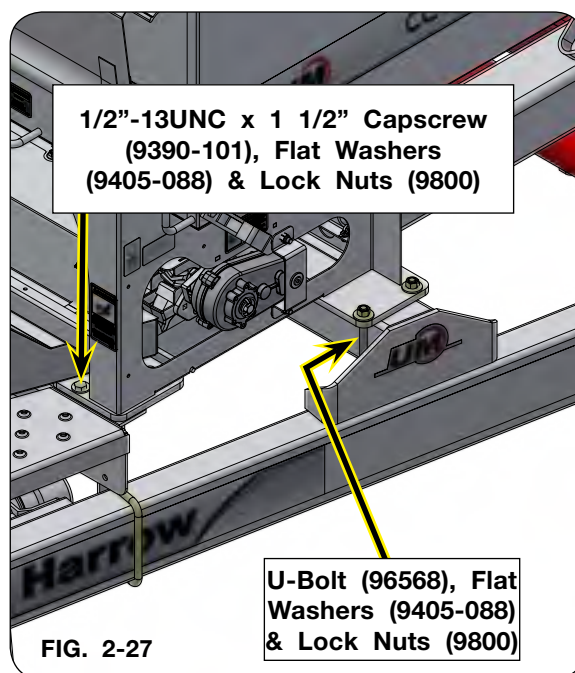

## Basic Set Up

### Hydraulics

1. Insert 90° elbow (97445) into the top of the fan motor. Fill the motor drain with clean hydraulic oil.
2. Attach the female end of the 3/8" x 288" hose (9002286) to the 90° elbow (97445). Route the male end of the hose to the tractor.

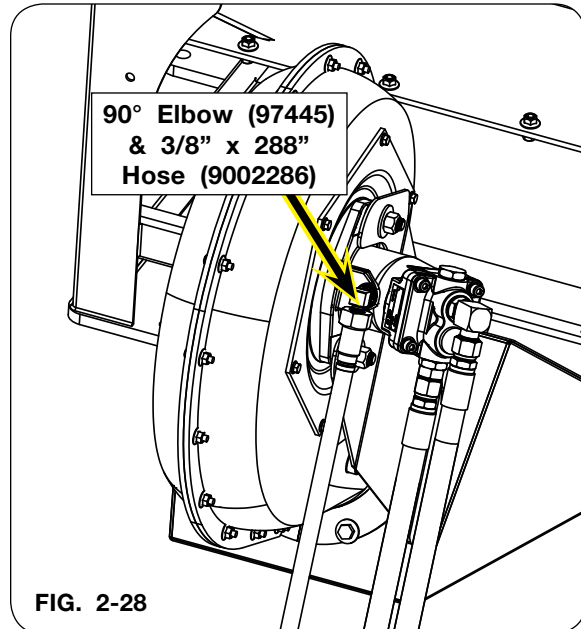

**NOTE:** Case drain plug must be steel not plastic.

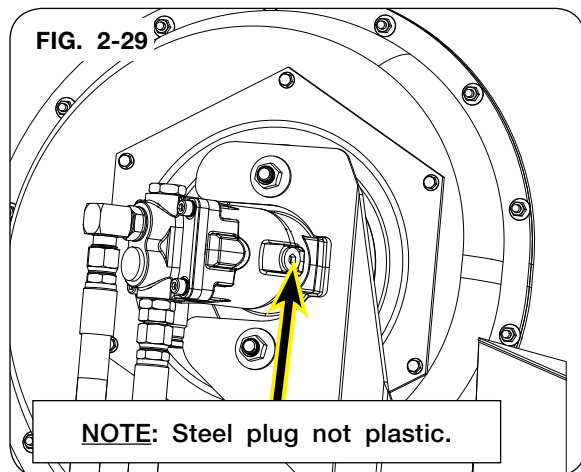

3. Assemble the coupler (9006048) to the male end of the 3/8" x 288" hose (9002286).

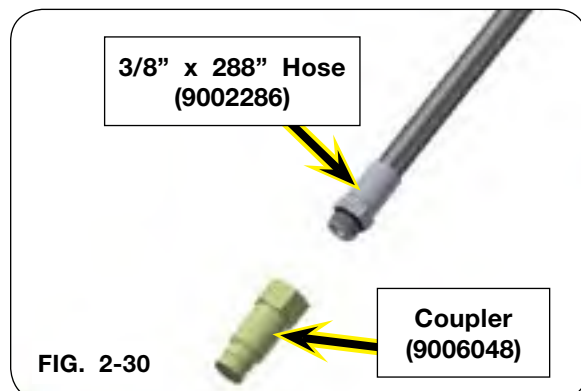



## Basic Set Up

### Hydraulics (continued)

4. Insert 7/8-14 JIC male x 7/8-14 o-ring male 90° elbow (95540) into the side of the fan motor. (FIG. 2-31)
5. Attach the 5/8" x 30" hose (9503989) to the 90° elbow (95540). (FIG. 2-31)
6. Insert 7/8-14 JIC male x 7/8-14 o-ring male adapter (9002443) into the end of the fan motor. (FIG. 2-31)
7. Attach the 5/8" x 30" hose (9503989) to the adapter (9002443). (FIG. 2-31)

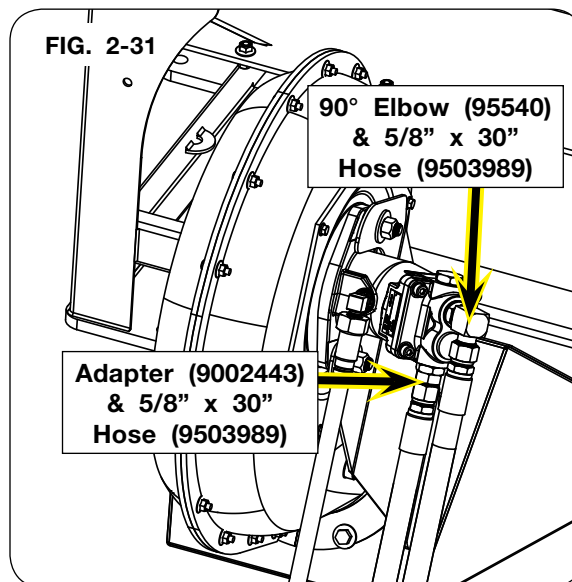

8. Assemble the 7/8-14 JIC male x 7/8-14 JIC male x 7/8-14 o-ring male tee (95541), check valve (902729), and 7/8-14 JIC male x 7/8-14 JIC female swivel tee (9002465) as shown in FIG. 2-32. Ensure check valve (902729) is teed with male JIC end to the fan return hose. Female o-ring side of check valve is on the pressure side of the system.

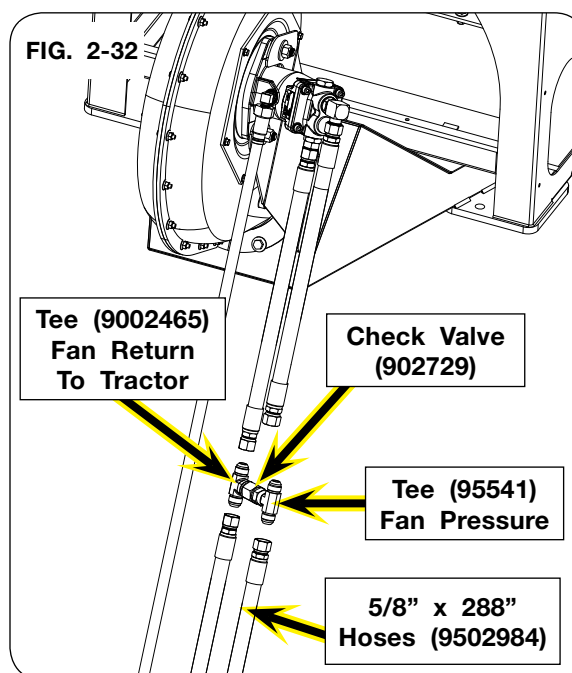

9. Secure the 5/8" x 30" hose (9503989) on the side of the fan motor to the 7/8-14 JIC male x 7/8-14 JIC male x 7/8-14 o-ring male tee (95541). (FIG. 2-32).
10. Secure the 5/8" x 30" hose (9503989) on the end of the fan motor to the 7/8-14 JIC male x 7/8-14 JIC male x 7/8-14 JIC female swivel tee (9002465). (FIG. 2-32)
11. Assemble the female ends of the 5/8" x 288" hoses (9502984) to the tees (FIG. 2-32). Route the male end of the hoses to the tractor.

## Basic Set Up

### Hydraulics (continued)

12. Assemble the coupler (95477) to the male end of the 5/8" x 288" hose (9502984) routed from fan pressure/side of fan motor. (FIG. 2-33)
13. Assemble the adapter (9503039) and low pressure return coupler (PF1202-8434) to the male end of the 5/8" x 288" hose (9502984) routed from fan return to tractor/end of fan motor. (FIG. 2-33)

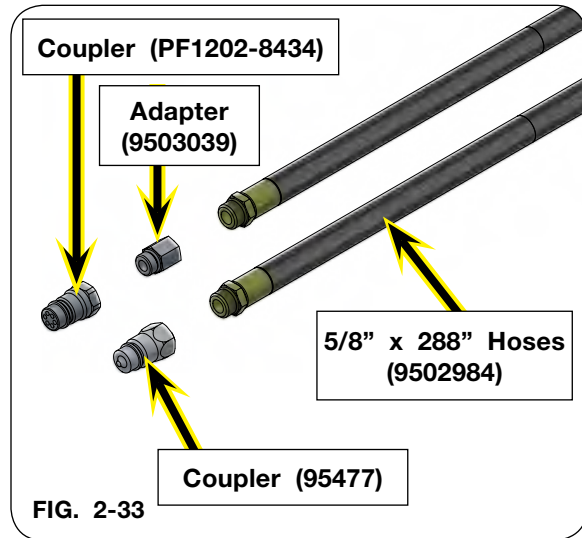

### Step

1. Loosely attach the step (78281B) to the Rolling Harrow main frame with one 1/2"-13UNC x 4 1/16" U-bolt (9502320) and two 1/2"-13UNC lock nuts (9800).
2. Secure the step (78281B) to the tank assembly with two 3/8"-16UNC x 1" capscrews (9390-055) and 3/8"-16UNC lock nuts (9928).
3. Rotate step up and secure with lynch pin (97442) before transporting.

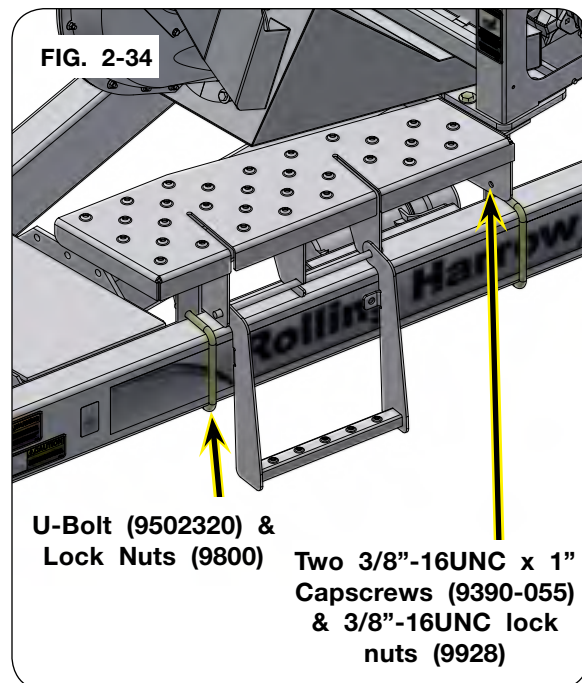

## Basic Set Up

### Gravity Latch Assembly

NOTE: ONLY Applicable for Rolling Harrow units with wing wheels.

#### **IMPORTANT**

- *Failure to install gravity latch assembly could result in damage to tire and/or cover crop seeder.*

1. Support the outer transport wheels.
2. Remove the rod end pin.
3. Install the gravity latch (88035B) and secure with 1" Dia. x 5 1/8" pins (88038) and 1/4" Dia. x 1 7/8" spiral pins (91144-165).

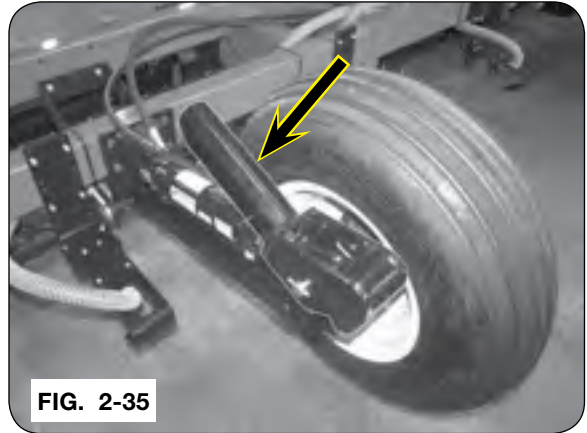

FIG. 2-35

## Basic Set Up

### ISO-BUS Rate Controller

#### Main Harness

1. Attach GEN 1 ISO to IBIC Hitch harness 24' (9009018) to optional harness extension (9504833) and baseline harness (9505095). (FIG. 2-36)

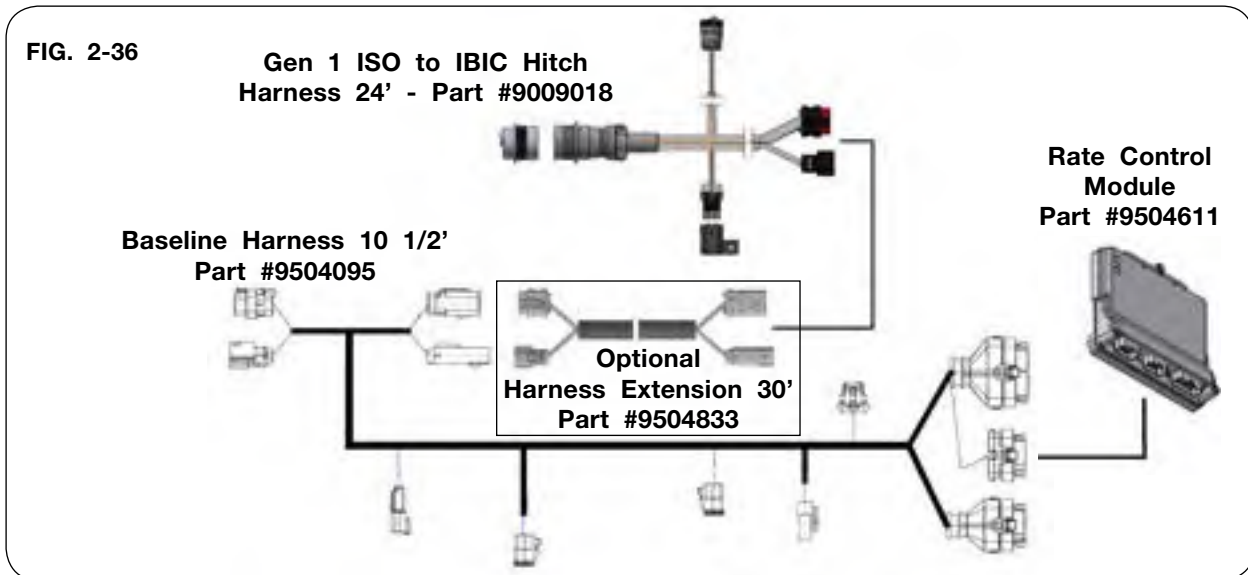

2. Connect the baseline harness (9504095) to the rate control module (9504611). (FIG. 2-36 & 2-37)



## Basic Set Up

### ISO-BUS Rate Controller (continued)

#### Foot Switch - Manual ON/OFF

1. Attach the foot switch (9005916) to the foot switch harness (9503390). (FIG. 2-38)
2. Connect foot switch harness (9503390) to GEN 1 ISO to IBIC hitch harness 24' (9009018).
3. Route GEN 1 ISO to IBIC hitch harness 24' (9009018) to tractor.

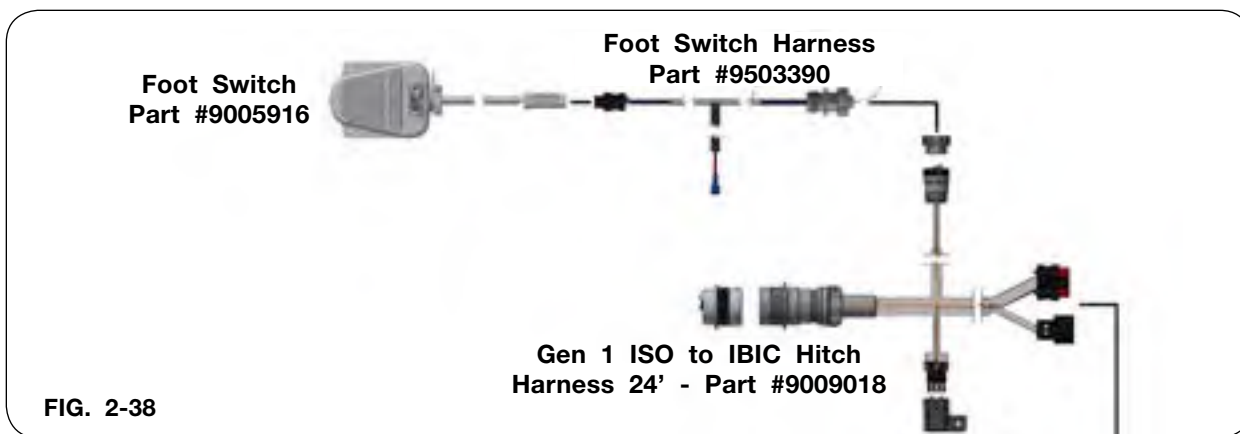

#### Fan Pressure Sensor

1. Attach the baseline harness (9504095) to the fan pressure sensor (9009382). (FIG. 2-39)

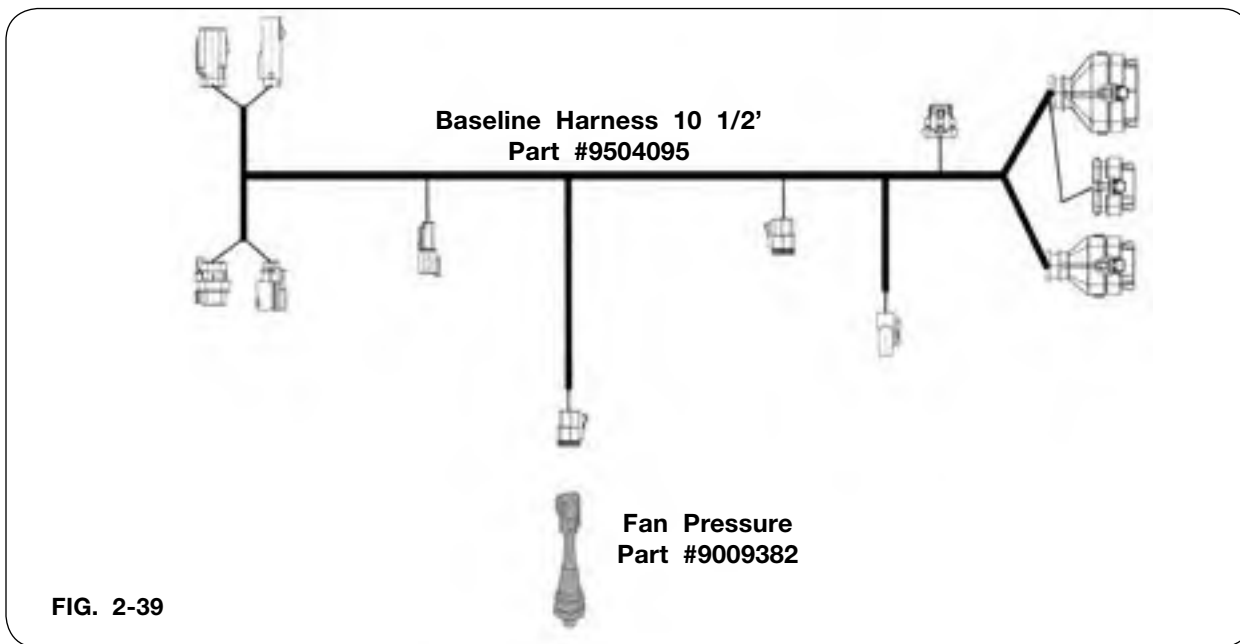

## Basic Set Up

### ISO-BUS Rate Controller (continued)

#### Bin Level Sensor

1. Attach the bin level sensor (9501978) to the bin level harness (79836). (FIG. 2-40)
2. Connect bin level harness (79836) to the baseline harness (9504095).

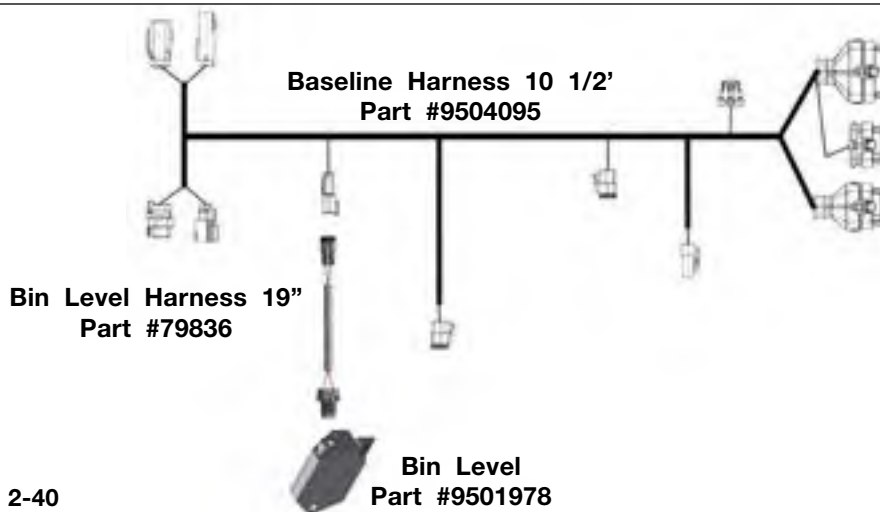

FIG. 2-40

#### Encoder

1. Attach the baseline harness (9504095) to the encoder (9009382). (FIG. 2-41)

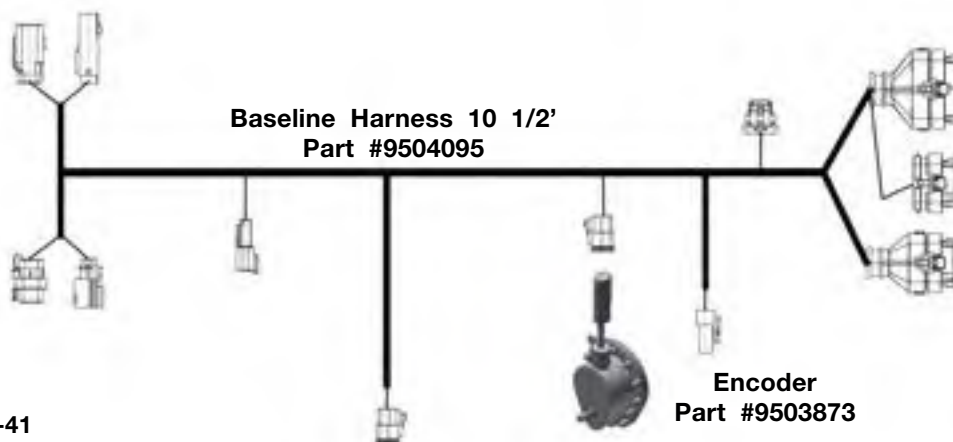

FIG. 2-41

## Basic Set Up

### ISO-BUS Rate Controller (continued)

#### Motor

1. Attach the baseline harness (9504095) to the motor (9504029). (FIG. 2-42)

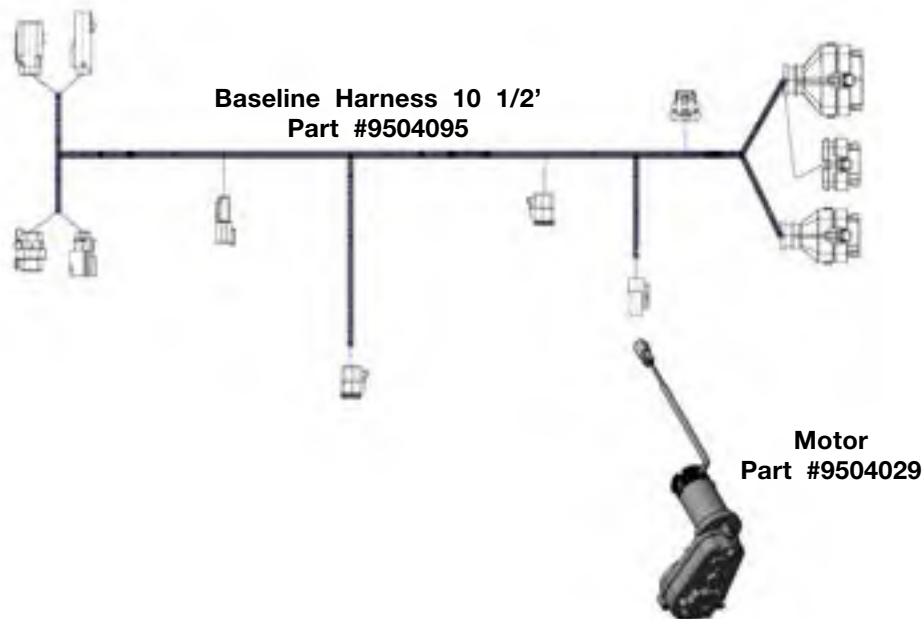

FIG. 2-42

## Basic Set Up

### ISO-BUS Rate Controller (continued)

#### Implement Switch/Proximity Sensor - Automatic ON/OFF

**NOTE:** If using the Implement Switch/Proximity Sensor (9006076) on the axle, it gets plugged into the baseline harness.

1. Attach the proximity mount bracket (77603B) with 1/2"-13UNC U-Bolts (96874) and 1/2"-13UNC lock nuts (9800).
2. Loosely assemble the pick-up bracket (77600B) to the axle with hose clamp (9502677).
3. Raise the Rolling Harrow until the baskets are barely off the ground.
4. Block the wheels on the machine to keep it from moving. Set the vehicle parking brake, shut off the engine and remove the ignition key. Use support stands rated at a minimum of 3000 lbs. to support the Rolling Harrow main frame.

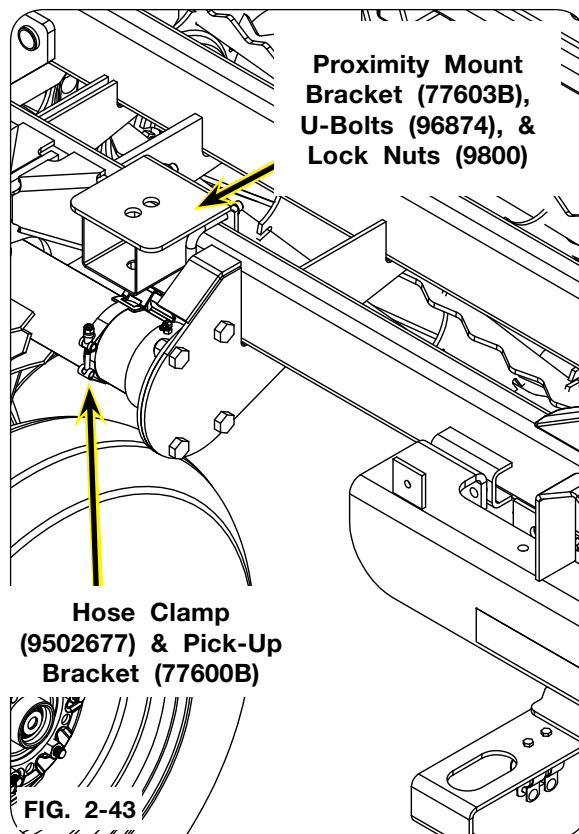



## Basic Set Up

### ISO-BUS Rate Controller (continued)

#### Implement Switch/Proximity Sensor - Automatic ON/OFF (continued)

5. Attach the implement switch/proximity sensor (9006076) to the proximity mount bracket (77603B) with jam nuts.
6. Rotate the pick-up bracket (77600B) until the light on the implement switch/proximity sensor (9006076) lights up. Tighten hose clamp (9502677) to secure pick-up bracket (77600B) in place.
7. Remove the support stands and lower Rolling Harrow to the ground. Set the vehicle parking brake, shut off the engine and remove the ignition key.
8. Route the implement switch/proximity sensor (9006076) wire along the left-side of the frame to the front of the seeder tank.
9. Connect the implement switch/proximity sensor (9006076) to the baseline harness.

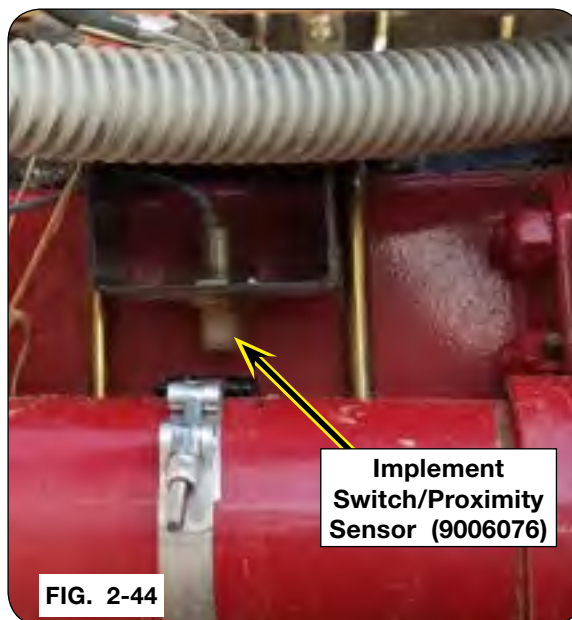
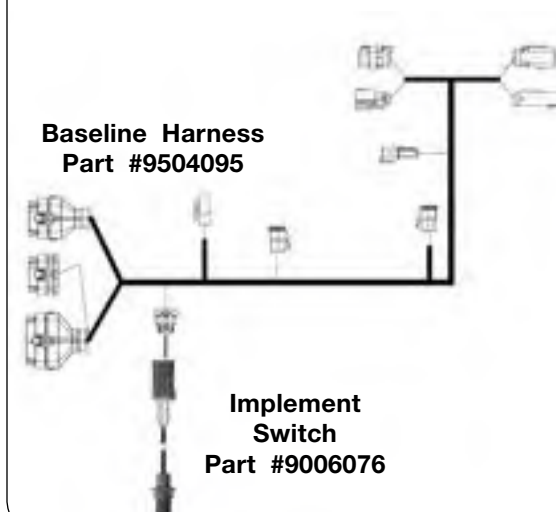

FIG. 2-45



## Basic Set Up

### Non ISO-BUS Variable Rate Controller

#### Main Harness and Optional Extension

1. Attach rate controller (9503931) to optional harness extension (9504329) or baseline harness (9503928). (FIG. 2-46)

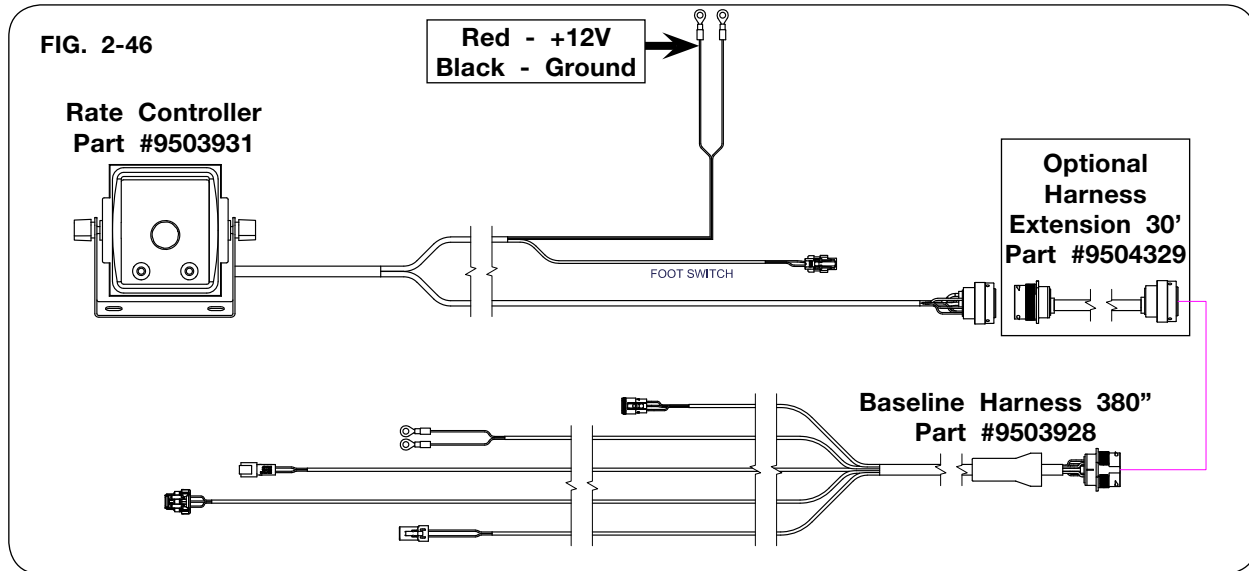

2. Connect rate controller (9503931) leads to power source. (FIG. 2-46)

#### Foot Switch - Manual ON/OFF

1. Attach the foot switch (9005916) to the rate controller (9503931). (FIG. 2-47)
2. Route rate controller (9503931) and foot switch (9005916) to tractor.

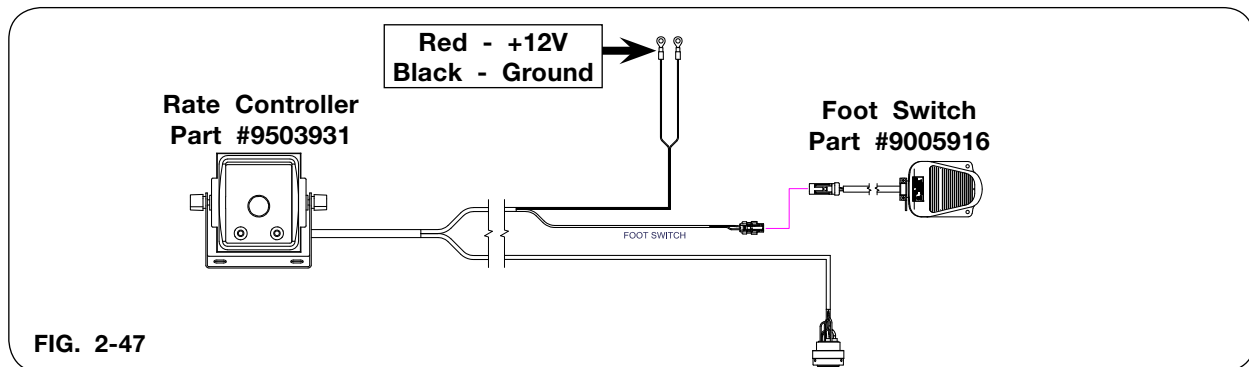

## Basic Set Up

### Non ISO-BUS Variable Rate Controller (continued)

#### Fan Pressure Sensor

1. Attach the baseline harness (9503928) to the fan pressure sensor (9502436). (FIG. 2-48)

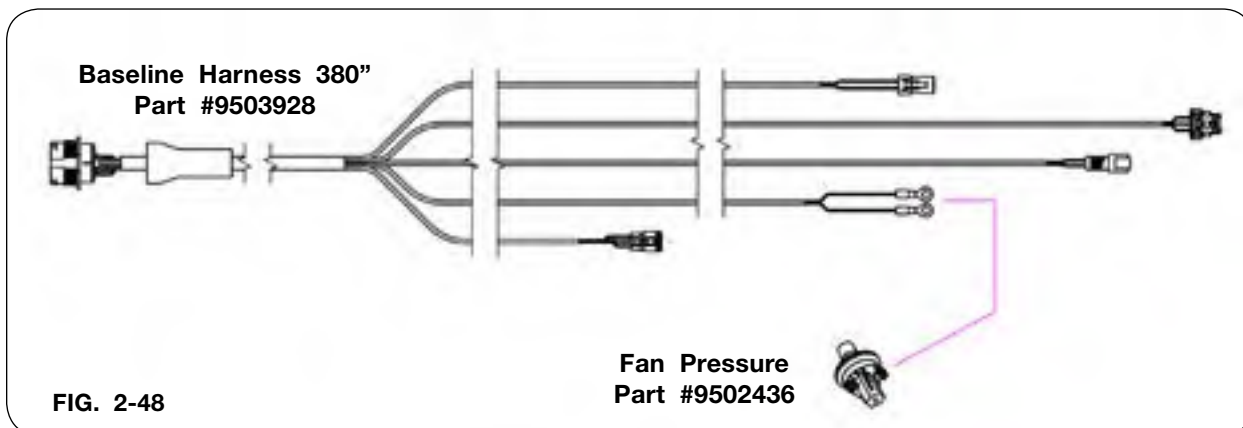

#### Bin Level Sensor

1. Attach the bin level sensor (9501978) to the bin level harness (79836). (FIG. 2-49)
2. Connect bin level harness (79836) to the baseline harness (9503928).

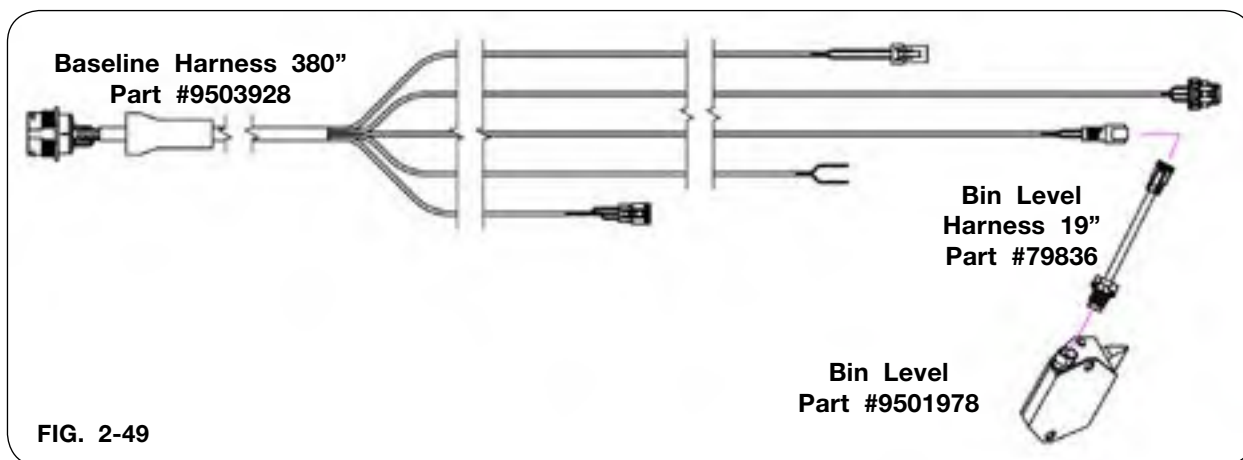

## Basic Set Up

### Non ISO-BUS Variable Rate Controller (continued)

#### Encoder

1. Attach the baseline harness (9503928) to the encoder (9503873). (FIG. 2-50)

Baseline Harness 380"  
Part #9503928

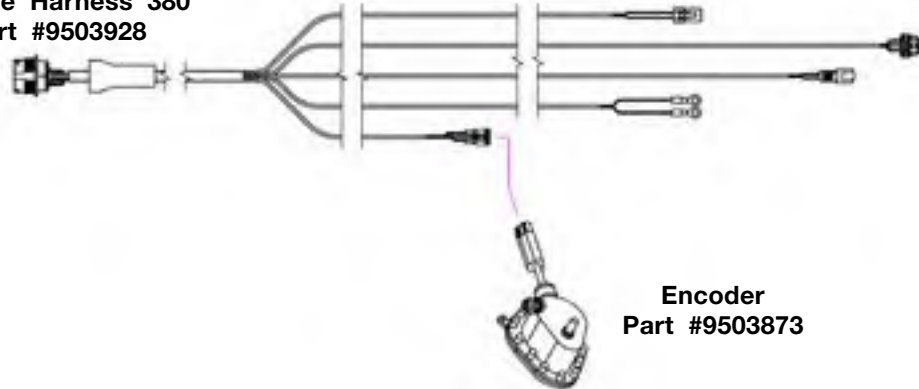

FIG. 2-50

#### Motor

1. Attach the baseline harness (9503928) to the motor (9504029). (FIG. 2-51)

FIG. 2-51

Baseline Harness 380"  
Part #9503928



## Basic Set Up

### Non ISO-BUS Variable Rate Controller (continued)

#### Implement Switch/Proximity Sensor - Automatic ON/OFF

**NOTE:** If using the Implement Switch/Proximity Sensor (9006076) on the axle, it gets plugged into the baseline harness.

1. Attach the proximity mount bracket (77603B) with 1/2"-13UNC U-Bolts (96874) and 1/2"-13UNC lock nuts (9800).
2. Loosely assemble the pick-up bracket (77600B) to the axle with hose clamp (9502677).
3. Raise the Rolling Harrow until the baskets are barely off the ground.
4. Block the wheels on the machine to keep it from moving. Set the vehicle parking brake, shut off the engine and remove the ignition key. Use support stands rated at a minimum of 3000 lbs. to support the Rolling Harrow main frame.

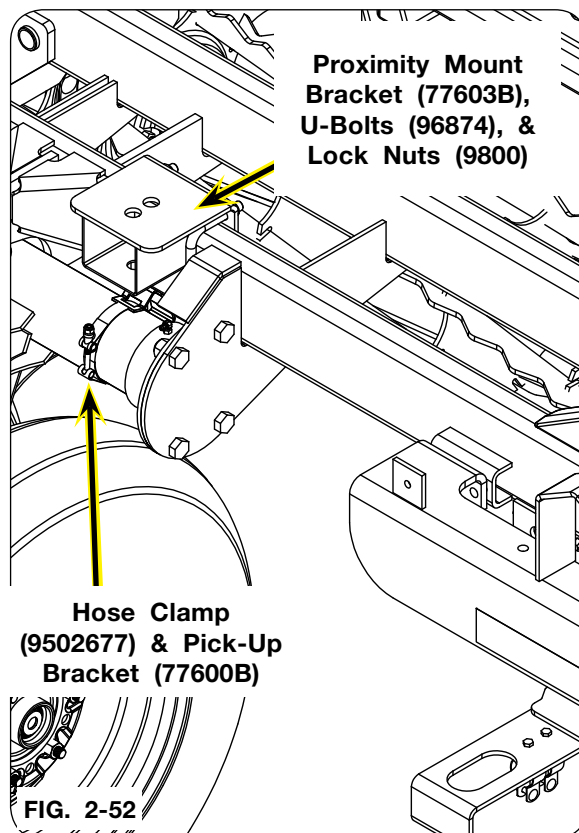

## Basic Set Up

### Non ISO-BUS Variable Rate Controller (continued)

#### Implement Switch/Proximity Sensor - Automatic ON/OFF (continued)

5. Attach the implement switch/proximity sensor (9006076) to the proximity mount bracket (77603B) with jam nuts.
6. Rotate the pick-up bracket (77600B) until the light on the implement switch/proximity sensor (9006076) lights up. Tighten hose clamp (9502677) to secure pick-up bracket (77600B) in place.
7. Remove the support stands and lower Rolling Harrow to the ground. Set the vehicle parking brake, shut off the engine and remove the ignition key.
8. Route the implement switch/proximity sensor (9006076) wire along the left-side of the frame to the front of the seeder tank.

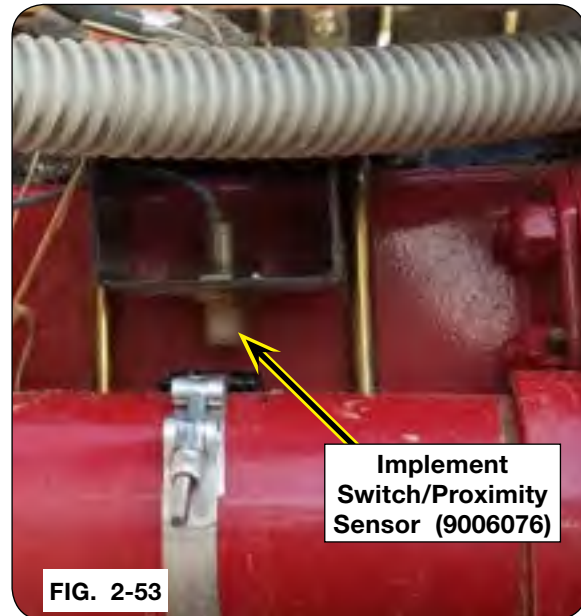
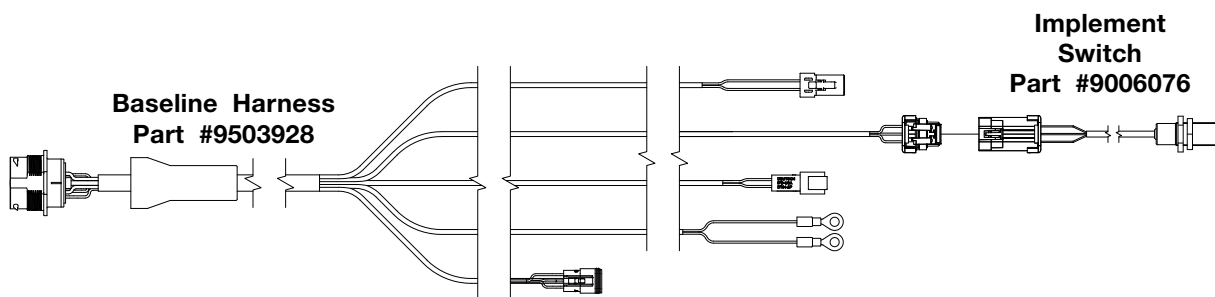

FIG. 2-53

9. Connect the implement switch/proximity sensor (9006076) to the baseline harness.

FIG. 2-54



## Basic Set Up

### Nozzles and Hose Placement and Routing

1. Refer to images below and Table 2.0 for the correct nozzle mounts and mounting hardware.

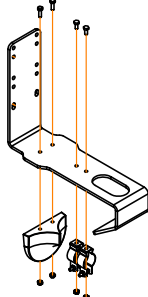
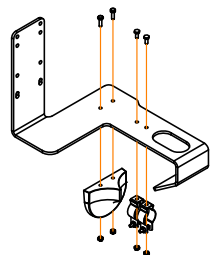
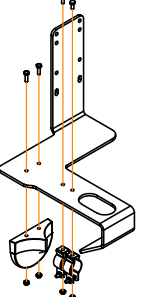
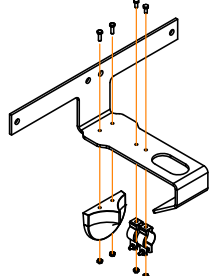
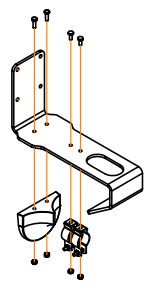
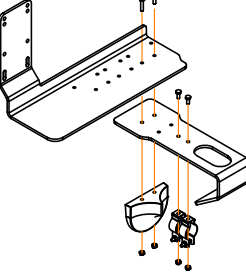
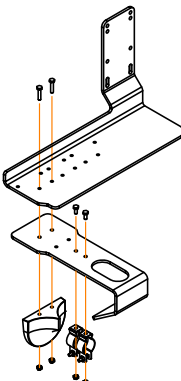
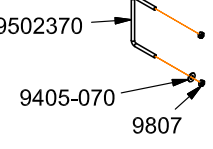
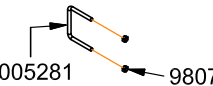
<p>Straight Nozzle Bracket Assembly (77625B)</p> 	<p>RH Nozzle Bracket Assembly (77712B)</p> 	<p>LH Nozzle Bracket Assembly (77713B)</p> 	<p>Straight Spliced Center Nozzle Bracket Assembly (78421B)</p> 
<p>Straight Center Nozzle Bracket Assembly (77850B)</p> 	<p>RH Nozzle Bracket (78145B) &amp; Bolt-Together Nozzle Bracket Assembly (78147B)</p> 	<p>LH Nozzle Bracket (78146B) &amp; Bolt-Together Nozzle Bracket Assembly (78147B)</p> 	<p>Mounting Hardware Used with ALL Nozzle Brackets Except Center Nozzle Brackets</p>  <p>9502370 9405-070 9807</p> <p>Mounting Hardware Used with Straight Center Nozzle Brackets ONLY</p>  <p>9005281 9807</p>

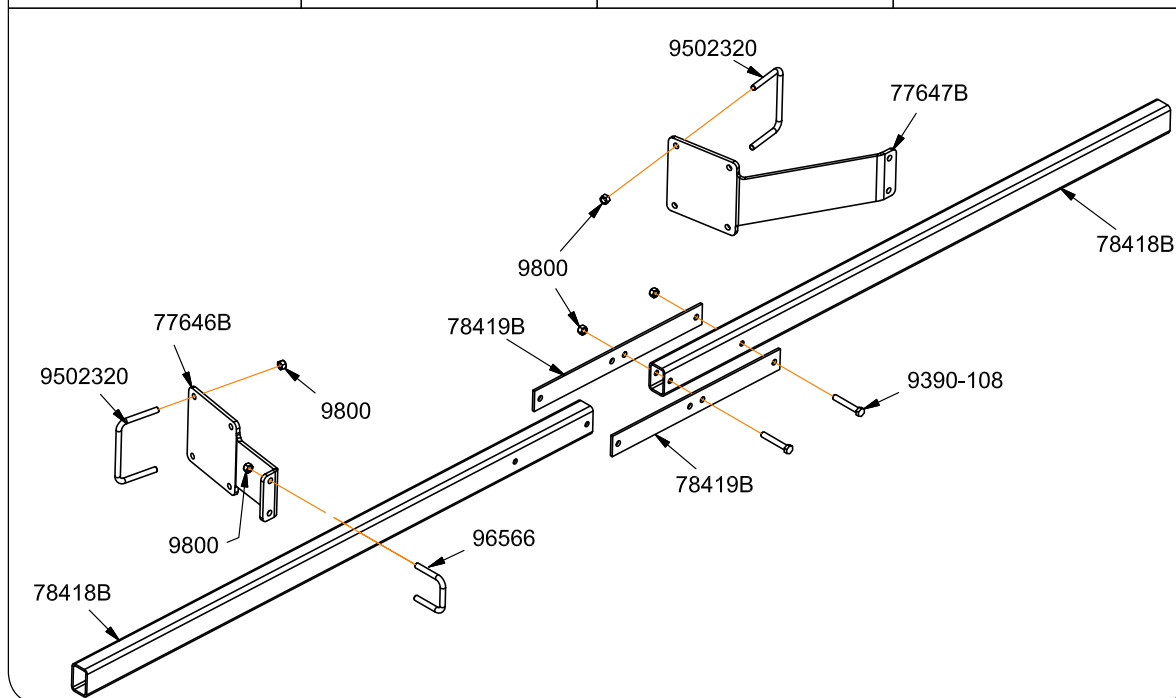

## Basic Set Up

### Nozzles and Hose Placement and Routing (continued)

Table 2.0

PART NUMBER	DESCRIPTION	QTY PER UNIT SIZE															
		18'	20'	21'	22'	23'	24'	25'	26'	27'	28'	29'	30'	31'	33'	35'	37'
77625B	Straight Nozzle Bracket Assembly	2	2	2	-	2	4	2	4	4	4	-	2	4	6	4	2
77712B	Right-Hand Nozzle Bracket Assembly	-	-	-	2	1	-	1	-	-	-	3	1	1	-	2	2
77713B	Left-Hand Nozzle Bracket Assembly	-	-	-	2	1	-	1	-	-	-	3	1	1	-	2	2
78421B	Straight Spliced Center Nozzle Bracket Assy	-	-	-	1	1	1	-	-	-	-	1	1	1	-	1	-
77850B	Straight Center Nozzle Bracket Assembly	4	4	4	2	2	2	4	4	4	4	2	2	2	4	2	4
78147B	Bolt-Together Nozzle Bracket Assembly	-	-	-	-	-	-	-	-	-	-	-	2	-	-	-	2
78146B	LH Nozzle Bracket (Long)	-	-	-	-	-	-	-	-	-	-	-	2	-	-	-	2
78145B	RH Nozzle Bracket (Long)	-	-	-	-	-	-	-	-	-	-	-	2	-	-	-	2
9502370	U-Bolt 5/16"-18UNC x 2 3/4" (5 1/16" ID)	4	4	4	8	8	8	8	8	8	8	12	12	12	12	16	16
9502320	U-Bolt 1/2"-13UNC x 4 1/16" (6 1/16" ID)	4	4	4	4	4	4	4	4	4	4	4	4	4	4	4	4
9807	Lock Nut 5/16"-18UNC	24	24	24	24	24	24	32	32	32	32	32	32	32	40	40	48
9800	Lock Nut 1/2"-13UNC	16	16	16	16	16	16	16	16	16	16	16	16	16	16	16	16
9405-070	Flat Washer 5/16" USS	4	4	4	8	8	8	8	8	8	8	12	12	12	12	16	16
78419B	Plate 2 1/4" x 21 5/8"	2	2	2	1	1	1	2	2	2	2	1	1	1	2	1	2
78418B	Tube 3" x 2" x 65 1/4"	2	2	2	2	2	2	2	2	2	2	2	2	2	2	2	2
9390-108	Capscrew 1/2"-13UNC x 3 1/4"	4	4	4	4	4	4	4	4	4	4	4	4	4	4	4	4
77647B	LH Tube Mount Plate	1	1	1	1	1	1	1	1	1	1	1	1	1	1	1	1
77646B	RH Tube Mount Plate	1	1	1	1	1	1	1	1	1	1	1	1	1	1	1	1
96566	U-Bolt 1/2"-13UNC x 3 1/4" (3 1/16" ID)	2	2	2	2	2	2	2	2	2	2	2	2	2	2	2	2
9005281	U-Bolt 5/16"-18UNC x 2 3/4" (3 1/16" ID)	8	8	8	4	4	4	8	8	8	8	4	4	4	8	4	8



## Basic Set Up

### Nozzles and Hose Placement and Routing (continued)

2. Refer to “Overhead Layouts” for proper positioning of nozzles.
3. Route the air hose from the nozzle brackets to the seed meter assembly. The hose should be flush with the end of the conduit clamp nearest to the nozzle.

**NOTE:** Hoses should not be kinked, twisted or rubbing against sharp edges. Re-route or repair hoses as necessary.

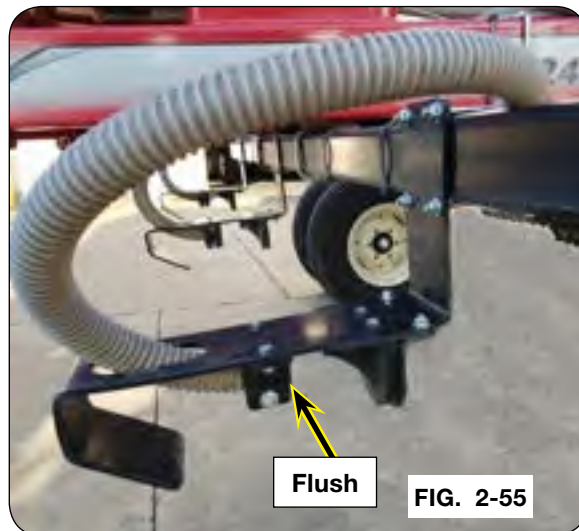

**Basic Set Up**

**Nozzles and Hose Placement and Routing (continued)**



**FIG. 2-57**

## Basic Set Up

### Nozzles and Hose Placement and Routing (continued)

4. Slide the hose over the end of the seed cup shaft end.

**NOTE:** Connect outer most nozzle hoses to the center most seed cups on the the tank. The center nozzle hoses will connect to the outer seed cups on the tank.

**NOTE:** On machines that do not have 12 nozzles, the unused seed cups need a plug (902944) inserted into the venturi nozzle.

5. Plug the seed cups that are not being used by removing the seed cup and venturi nozzle from the bottom of the seed meter assembly. Insert a plug (902944) into the venturi nozzle. Replace the seed cup and venturi nozzle back into the seed meter.



FIG. 2-58

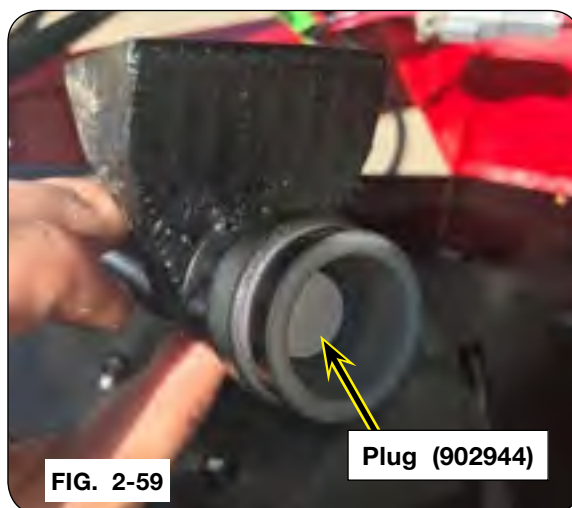

FIG. 2-59

Plug (902944)



**Basic Set Up**

**Nozzles and Hose Placement and Routing (continued)**



# Cover Crop Seeder — Set Up

## Overhead Layouts

### 18' Unit with 6 Deflector Nozzles

Dimensions Center of Nozzle to Center of Nozzle

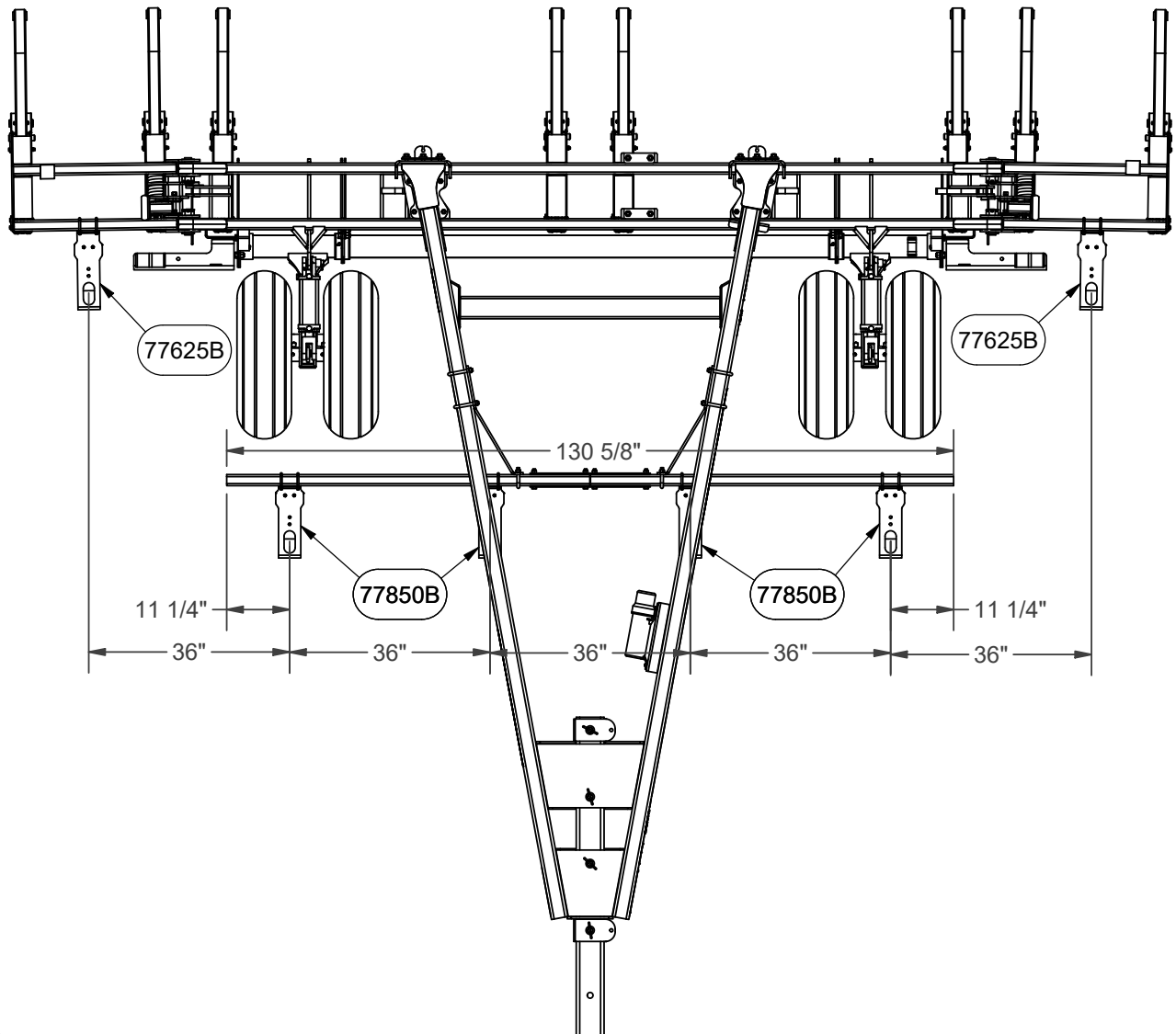

# Cover Crop Seeder — Set Up

## Overhead Layouts

### 20' Unit with 6 Deflector Nozzles

Dimensions Center of Nozzle to Center of Nozzle

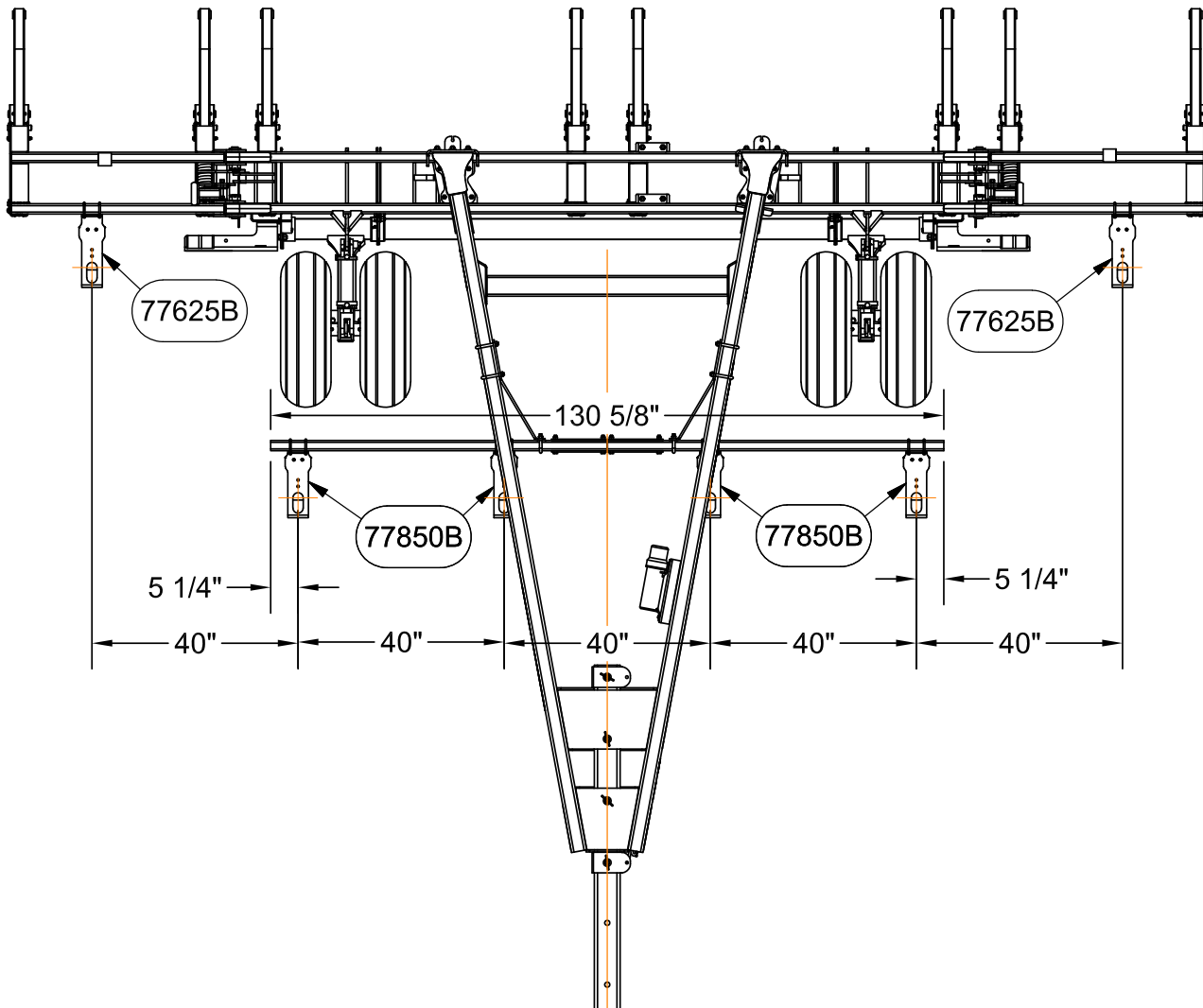

# Cover Crop Seeder — Set Up

## Overhead Layouts

### 21' Unit with 6 Deflector Nozzles

Dimensions Center of Nozzle to Center of Nozzle

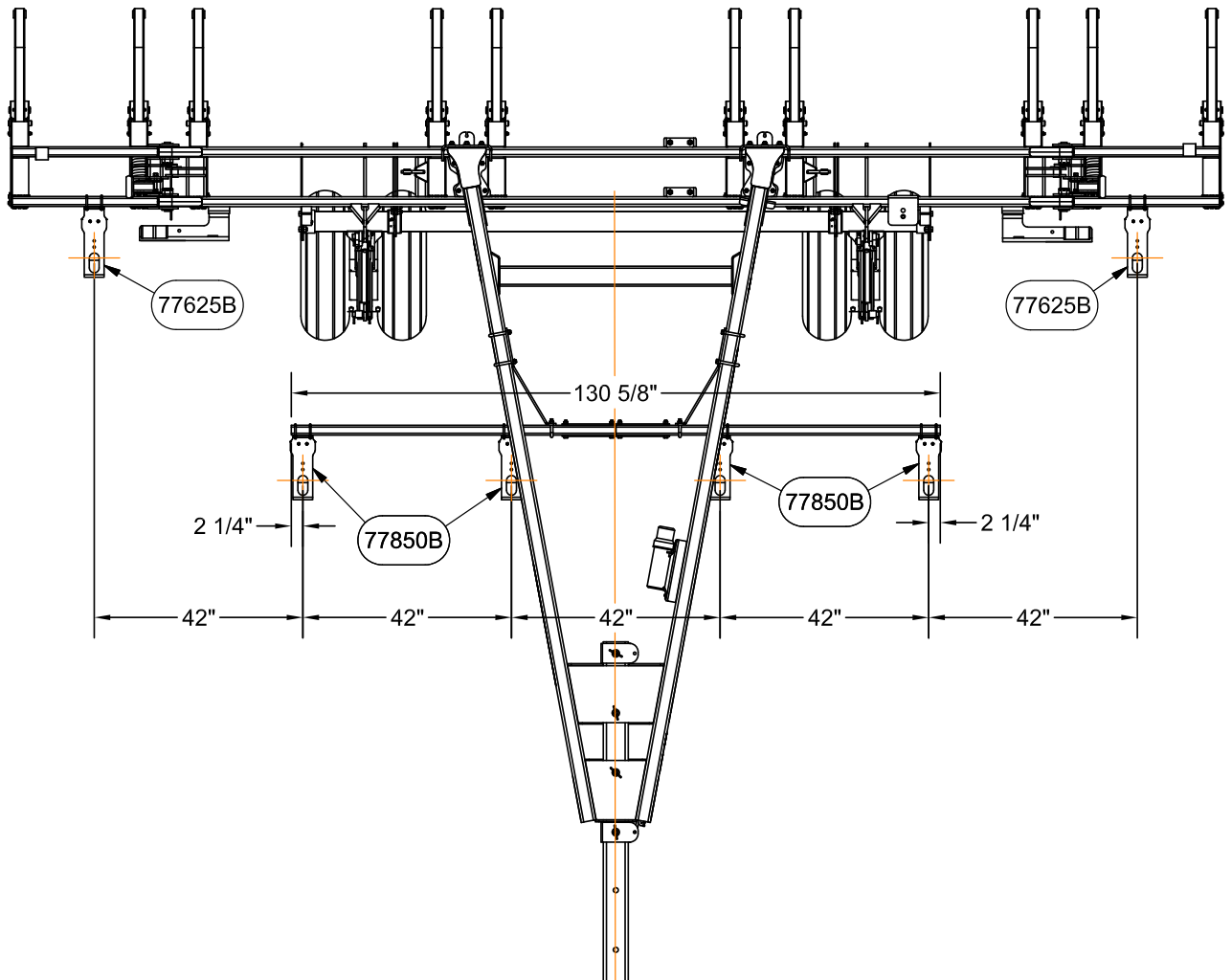



## Overhead Layouts

### 22' Unit with 7 Deflector Nozzles

Dimensions Center of Nozzle to Center of Nozzle

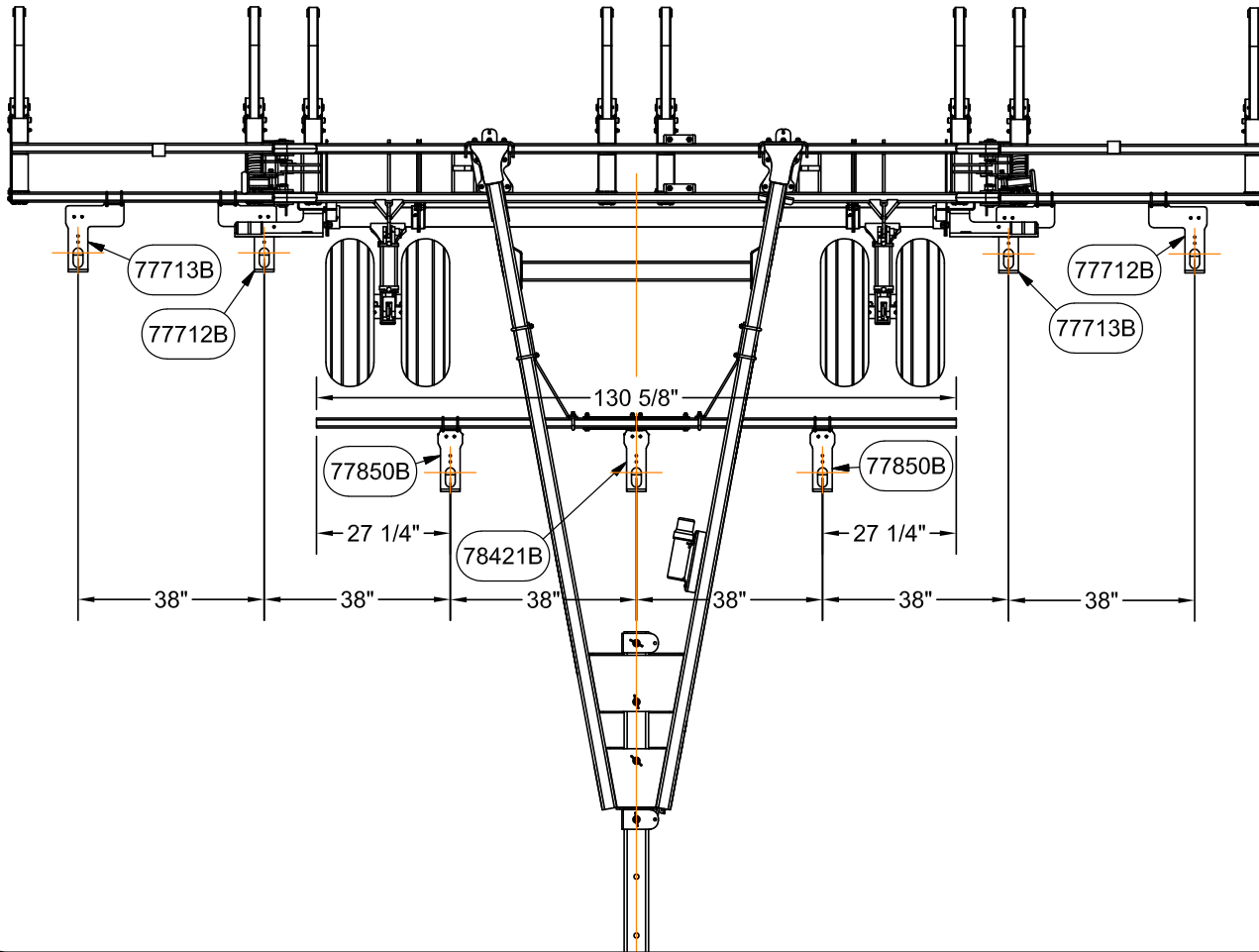

# Cover Crop Seeder — Set Up

## Overhead Layouts

### 23' Unit with 7 Deflector Nozzles

Dimensions Center of Nozzle to Center of Nozzle

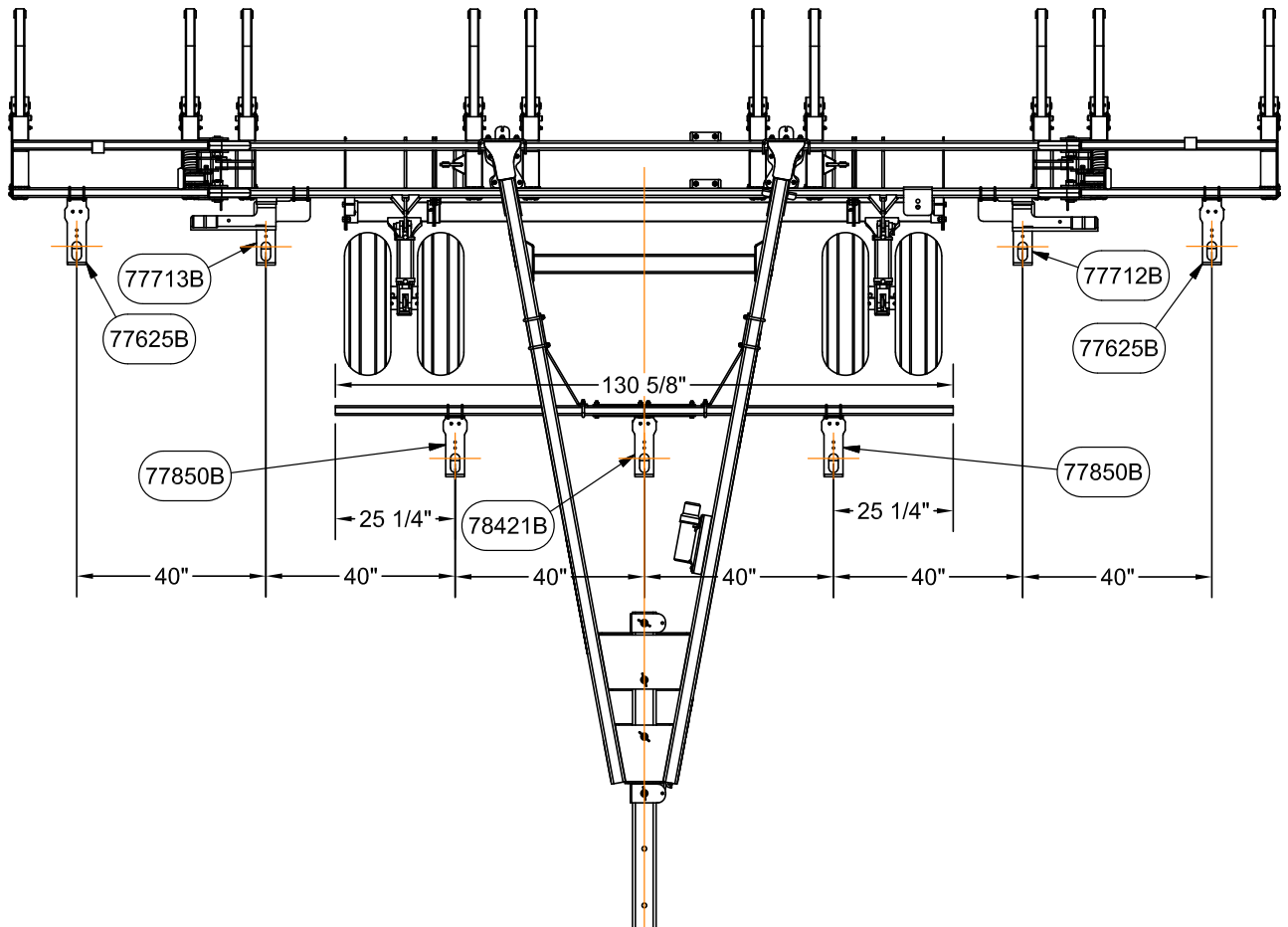

## Overhead Layouts

### 24' Unit with 7 Deflector Nozzles

Dimensions Center of Nozzle to Center of Nozzle

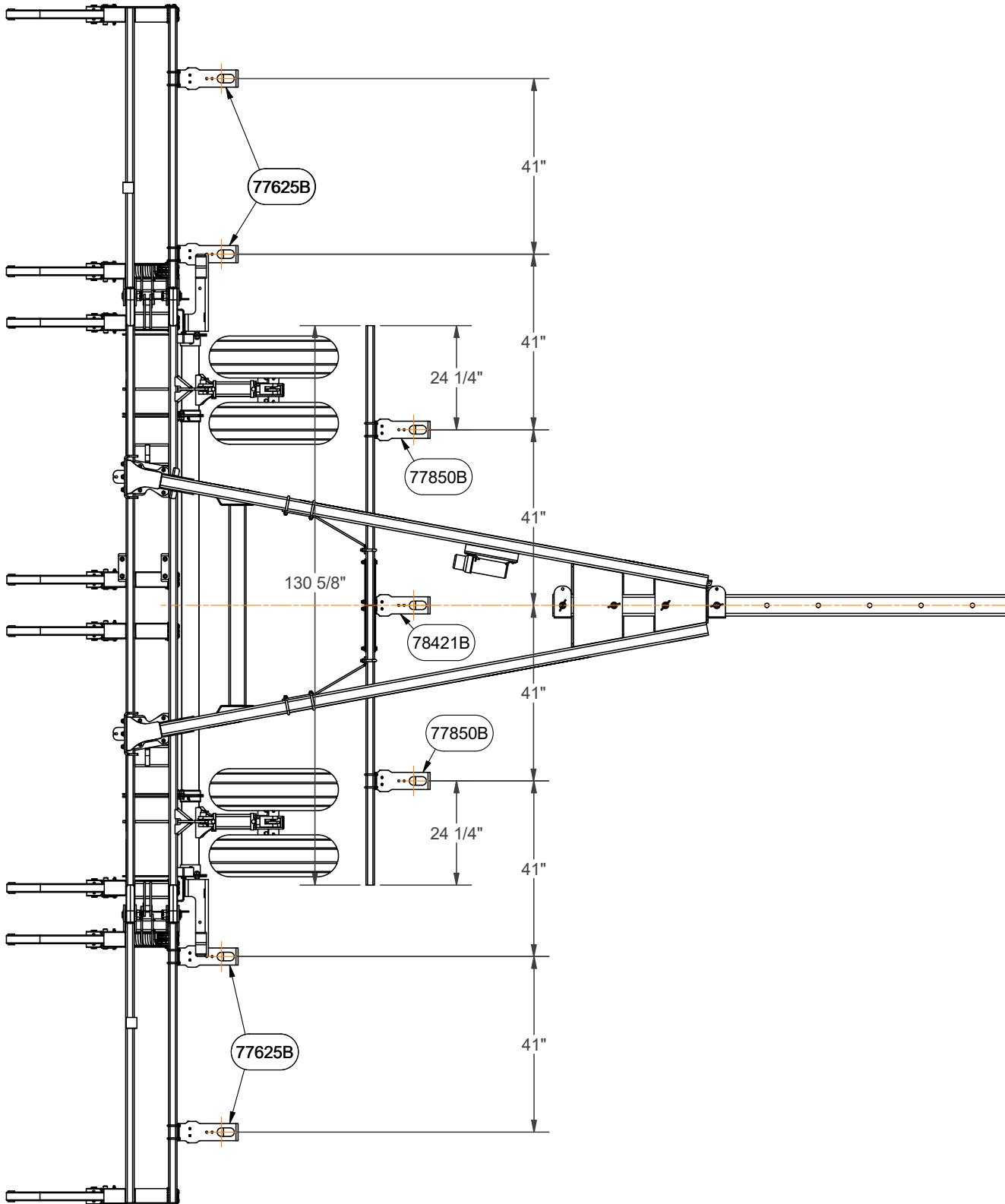

## Overhead Layouts

### 25' Unit with 8 Deflector Nozzles

Dimensions Center of Nozzle to Center of Nozzle

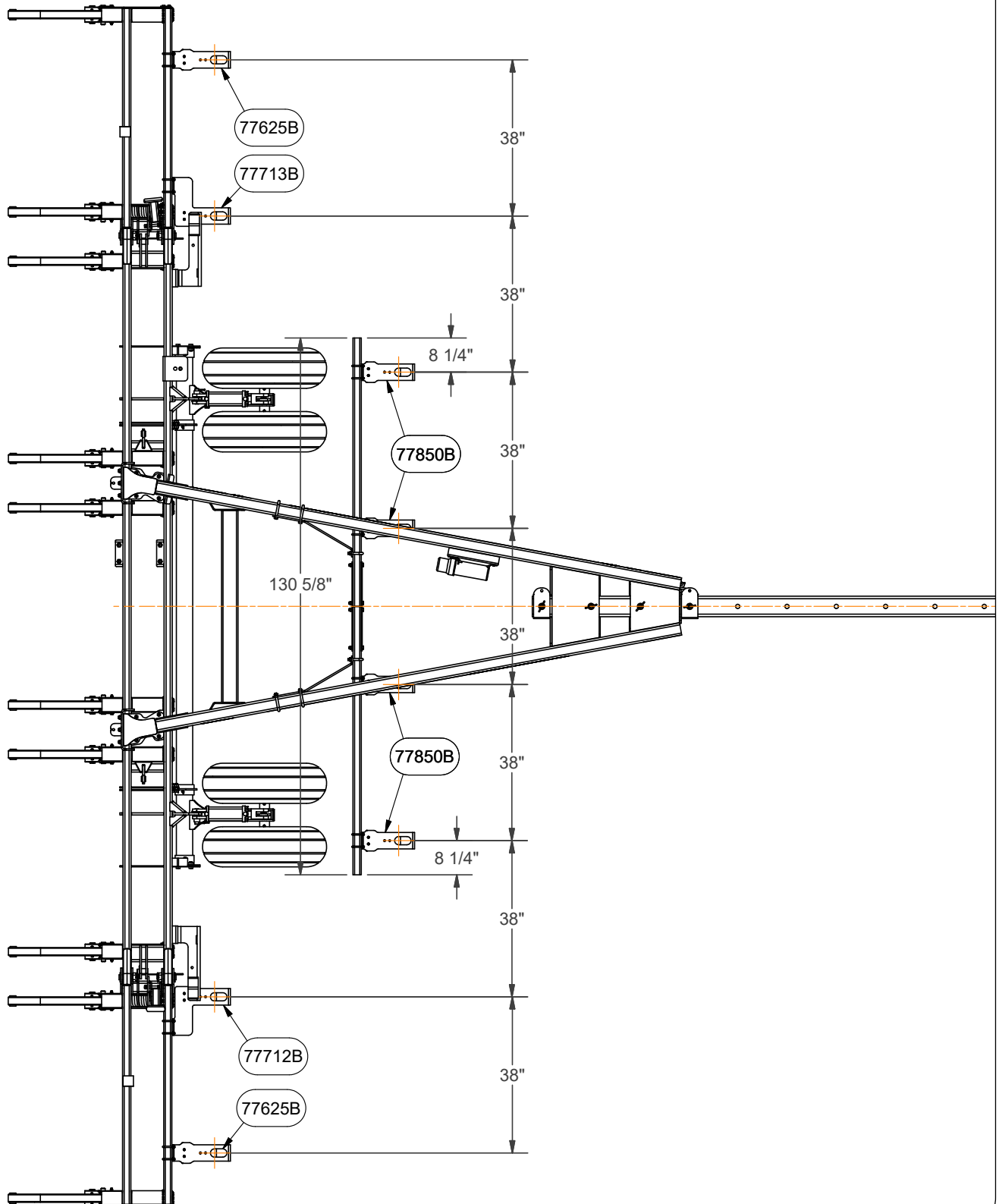

## Overhead Layouts

### 26' Unit with 8 Deflector Nozzles

Dimensions Center of Nozzle to Center of Nozzle

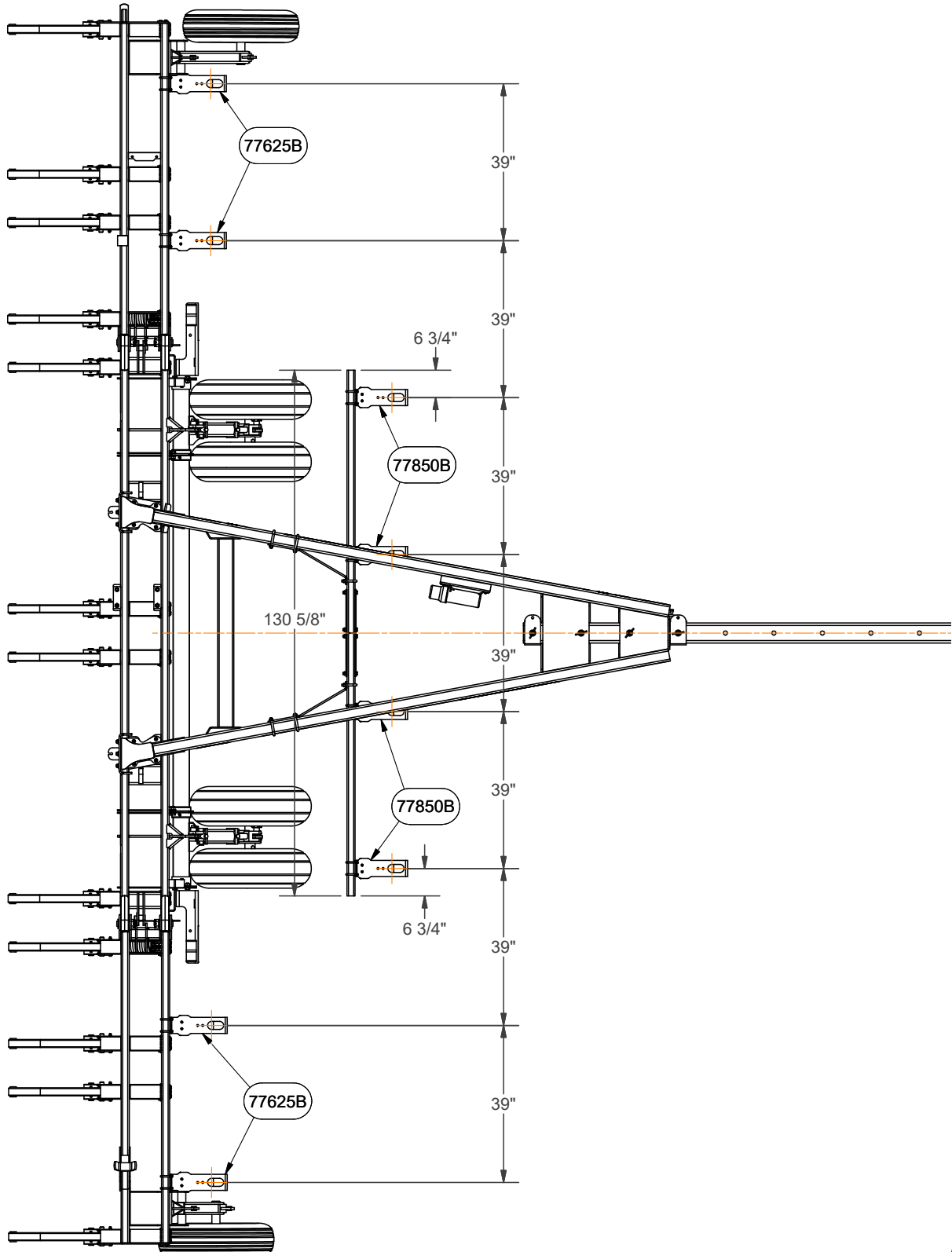

## Overhead Layouts

### 27' Unit with 8 Deflector Nozzles

Dimensions Center of Nozzle to Center of Nozzle

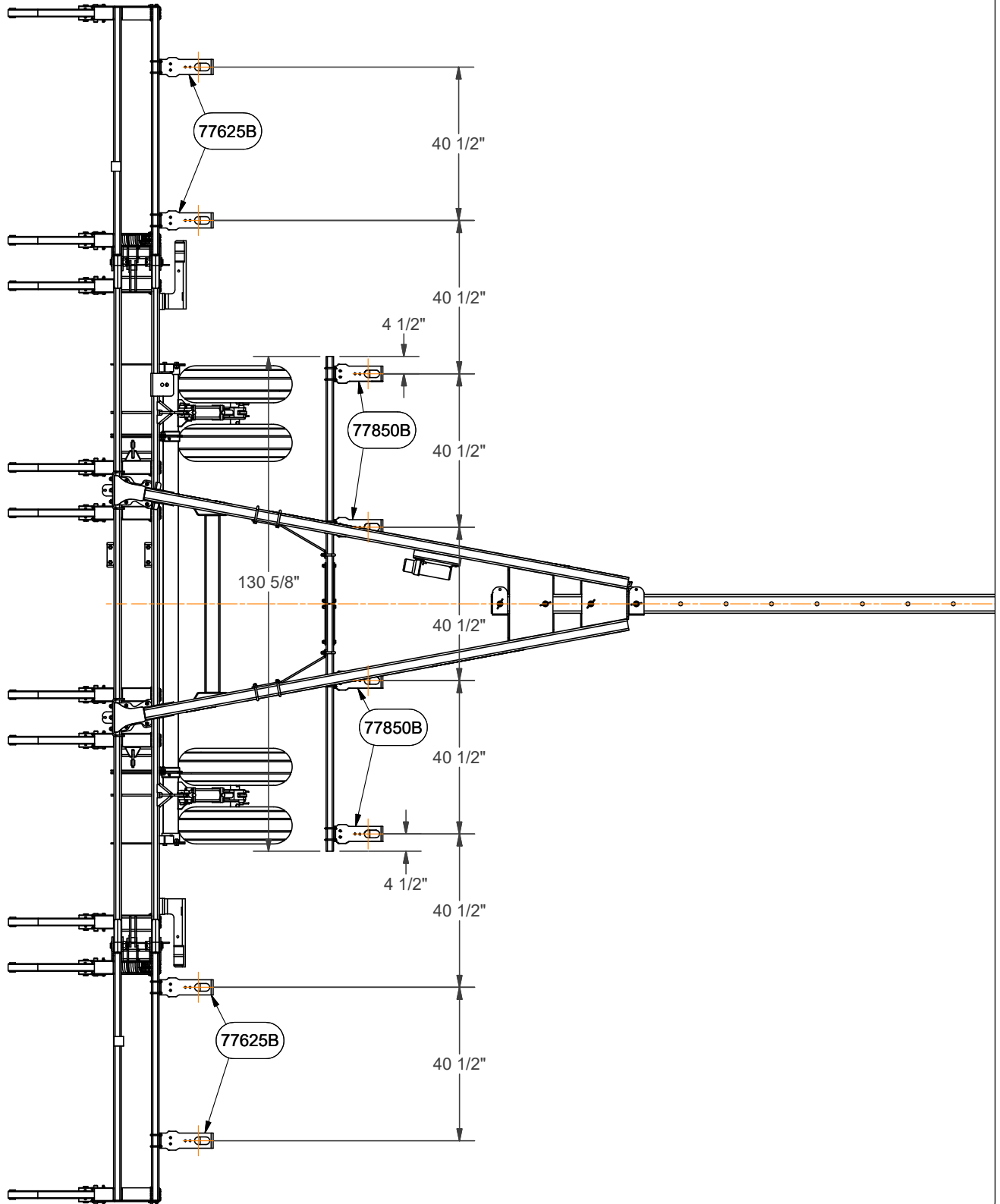

## Overhead Layouts

### 28' Unit with 8 Deflector Nozzles

Dimensions Center of Nozzle to Center of Nozzle

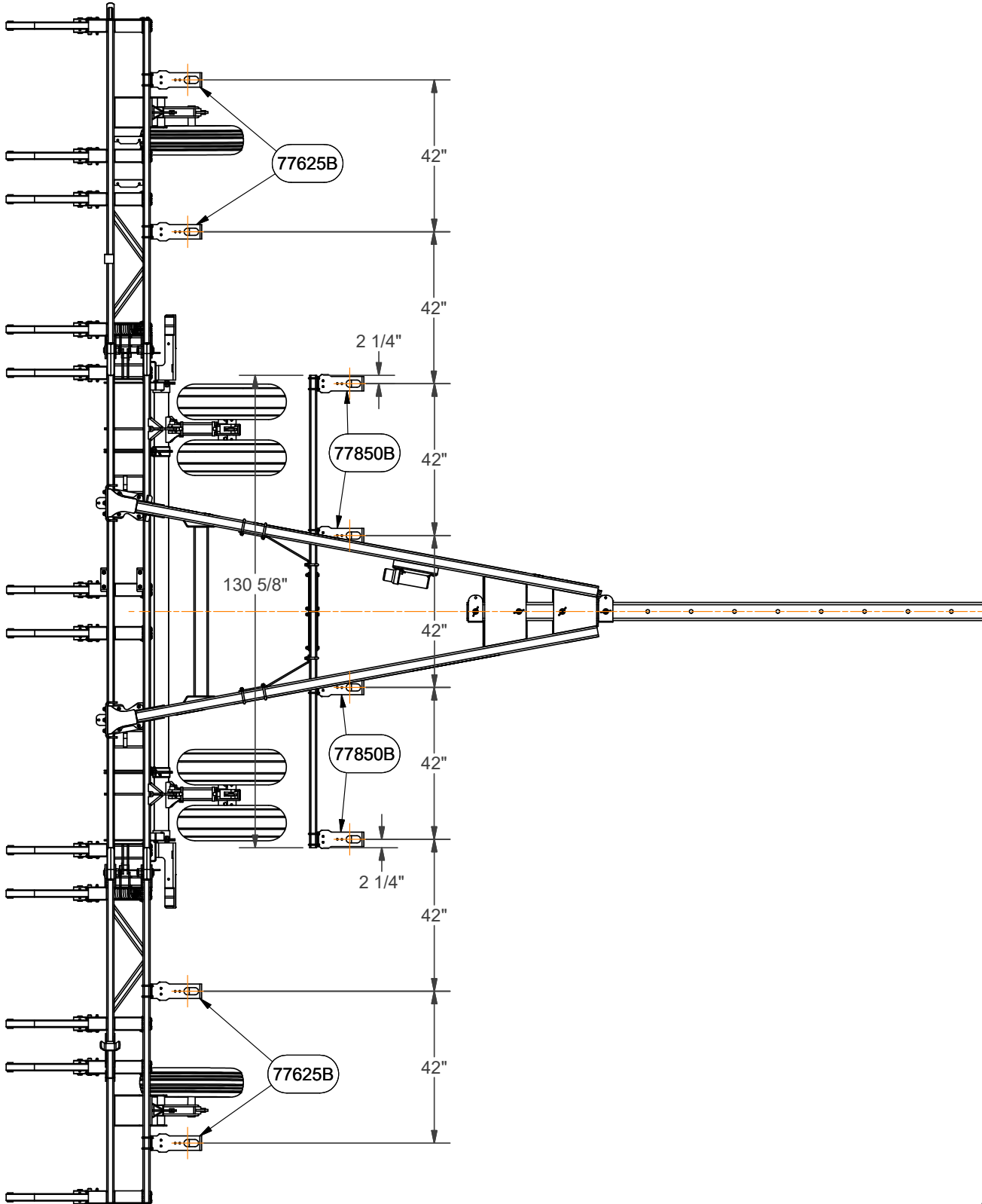



## Overhead Layouts

### 29' Unit with 9 Deflector Nozzles

Dimensions Center of Nozzle to Center of Nozzle

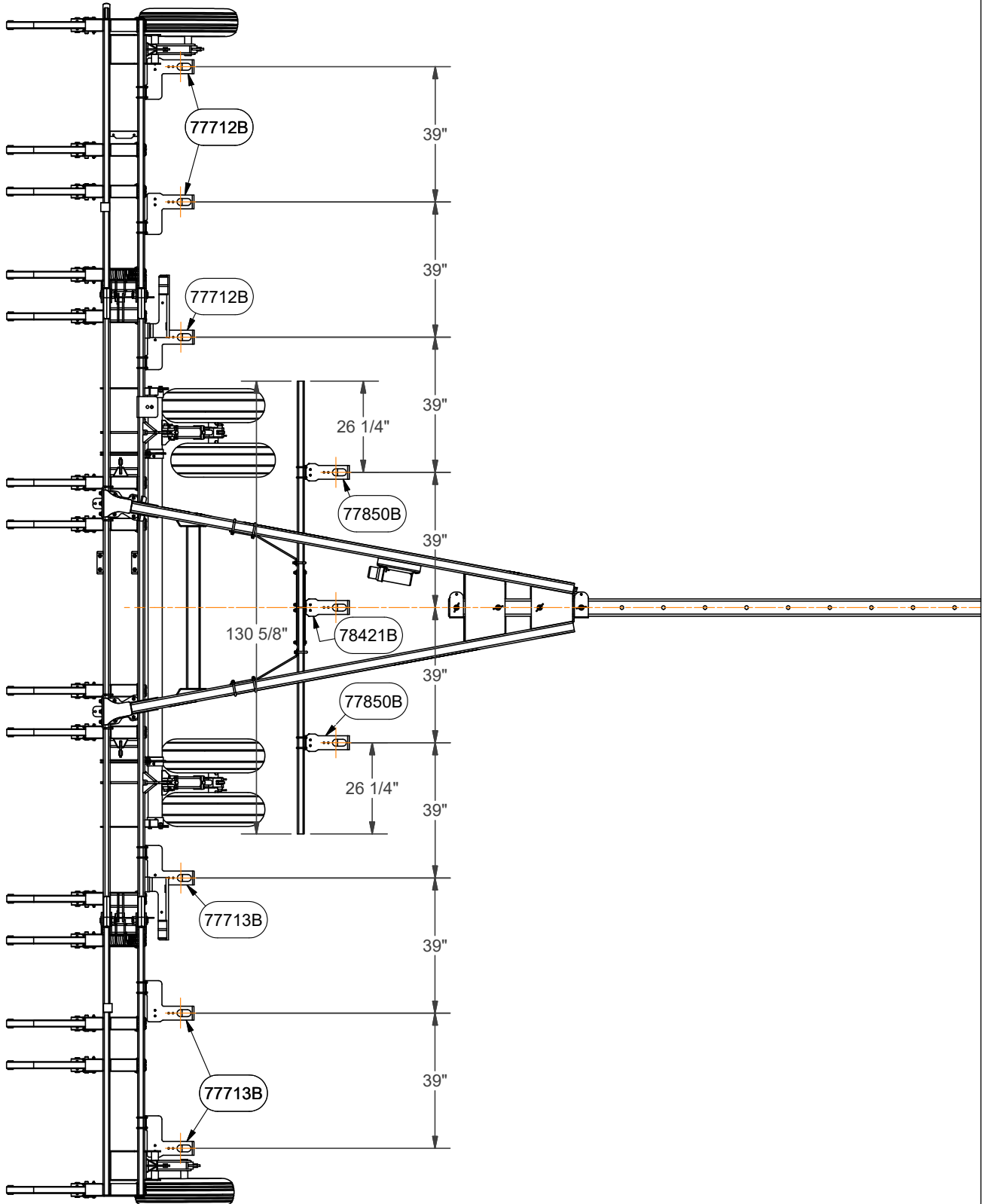

## Overhead Layouts

### 30' Unit with 9 Deflector Nozzles

Dimensions Center of Nozzle to Center of Nozzle

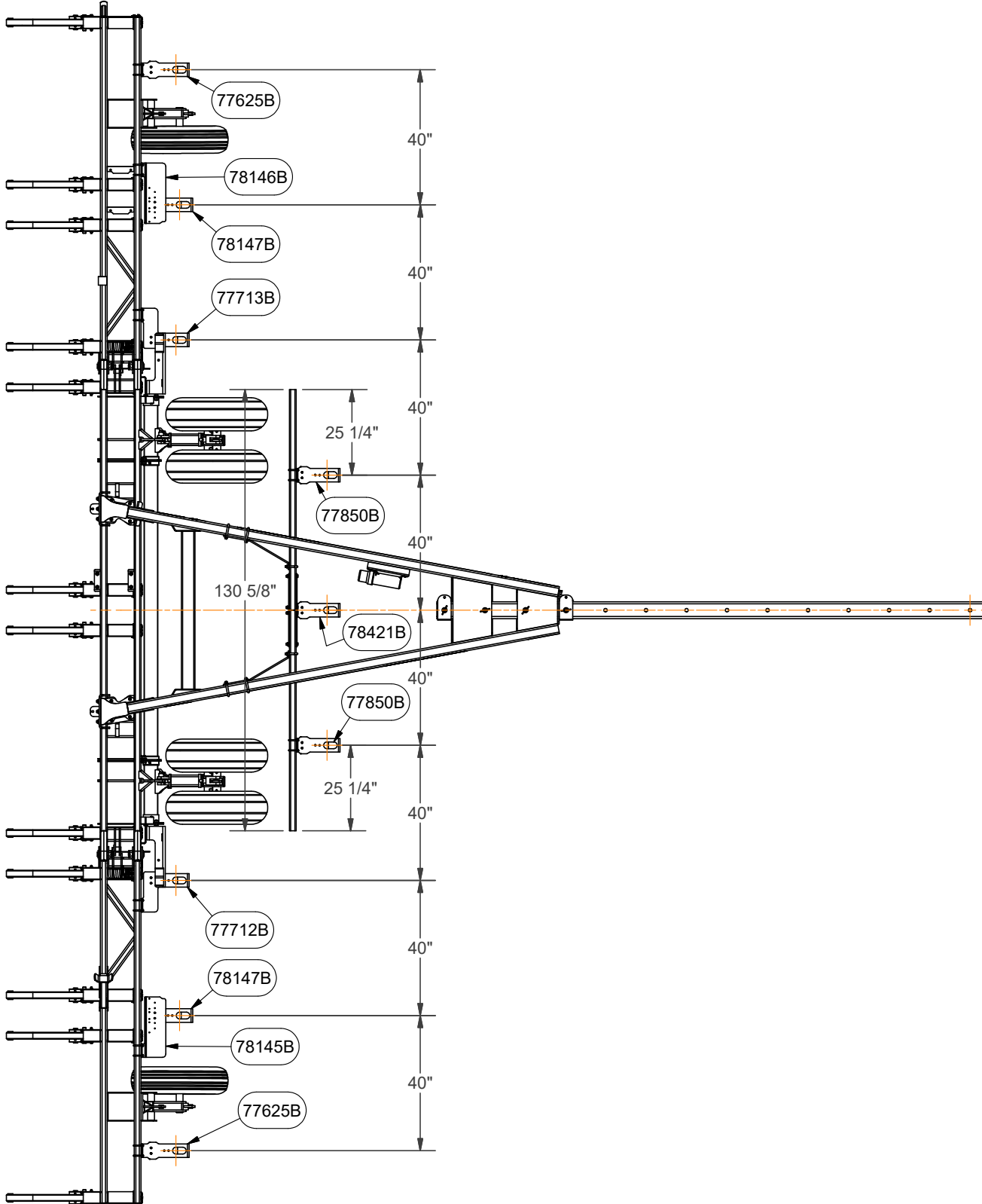

## Overhead Layouts

### 31' Unit with 9 Deflector Nozzles

Dimensions Center of Nozzle to Center of Nozzle

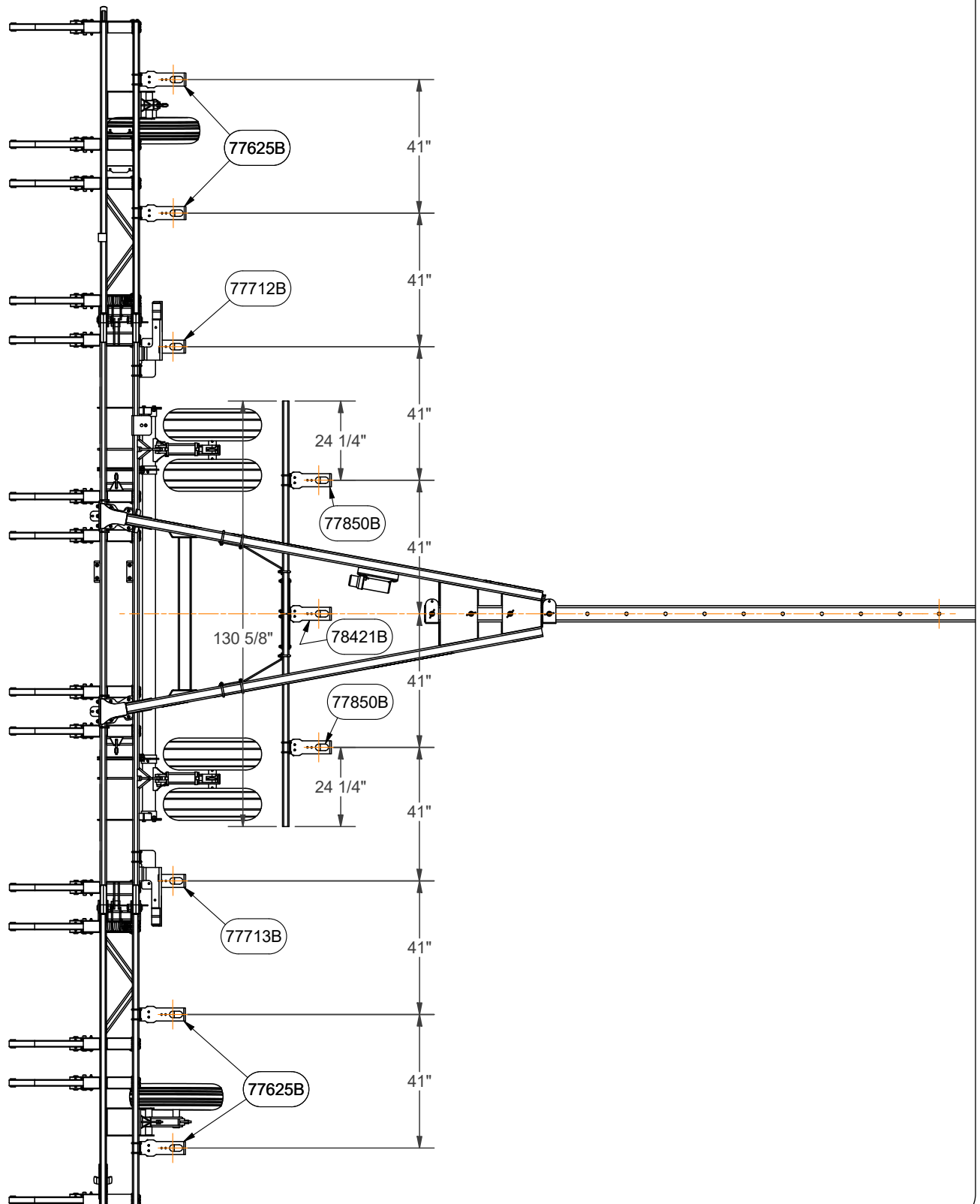

## Overhead Layouts

### 33' Unit with 10 Deflector Nozzles

Dimensions Center of Nozzle to Center of Nozzle

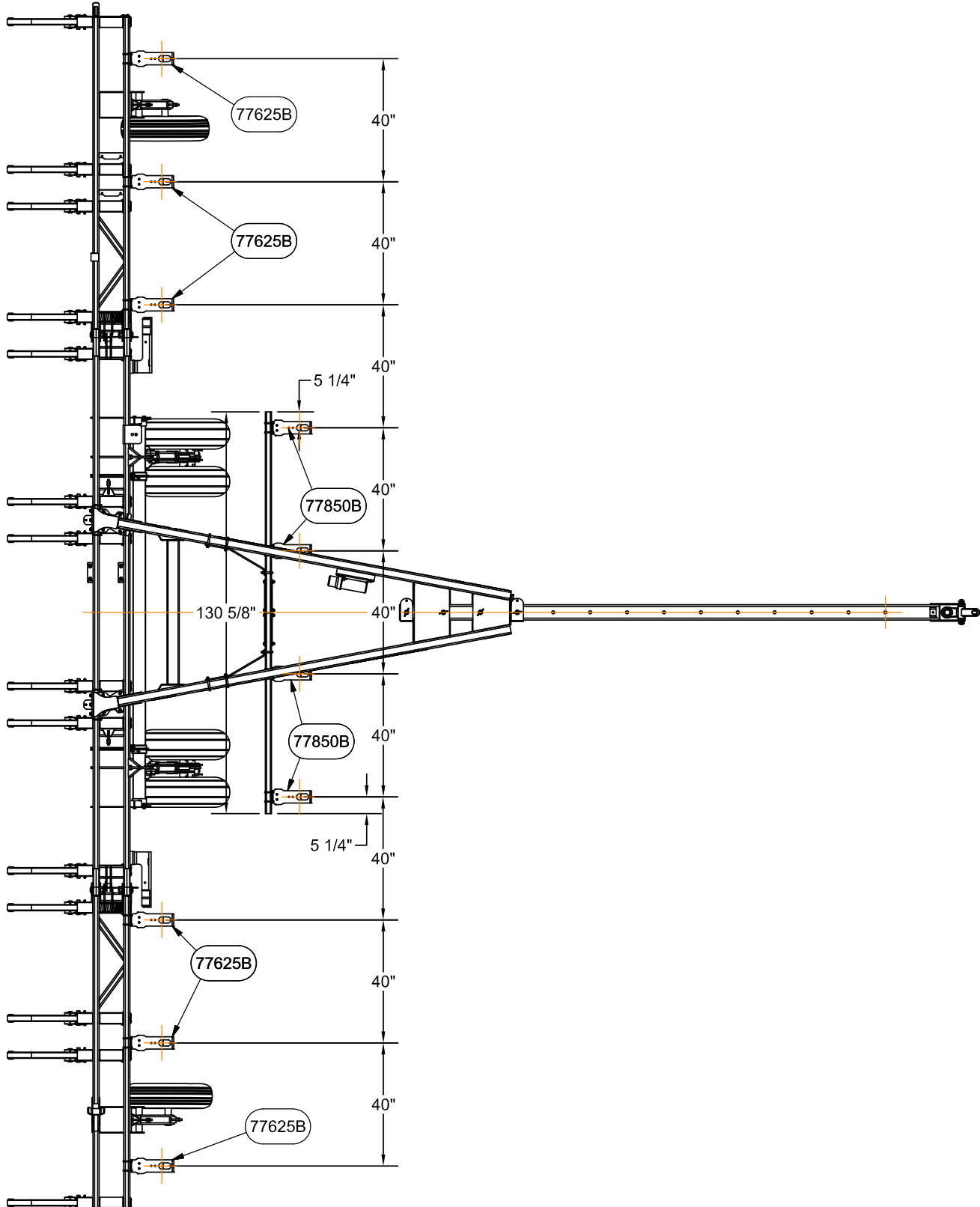

## Overhead Layouts

### 35' Unit with 11 Deflector Nozzles

Dimensions Center of Nozzle to Center of Nozzle

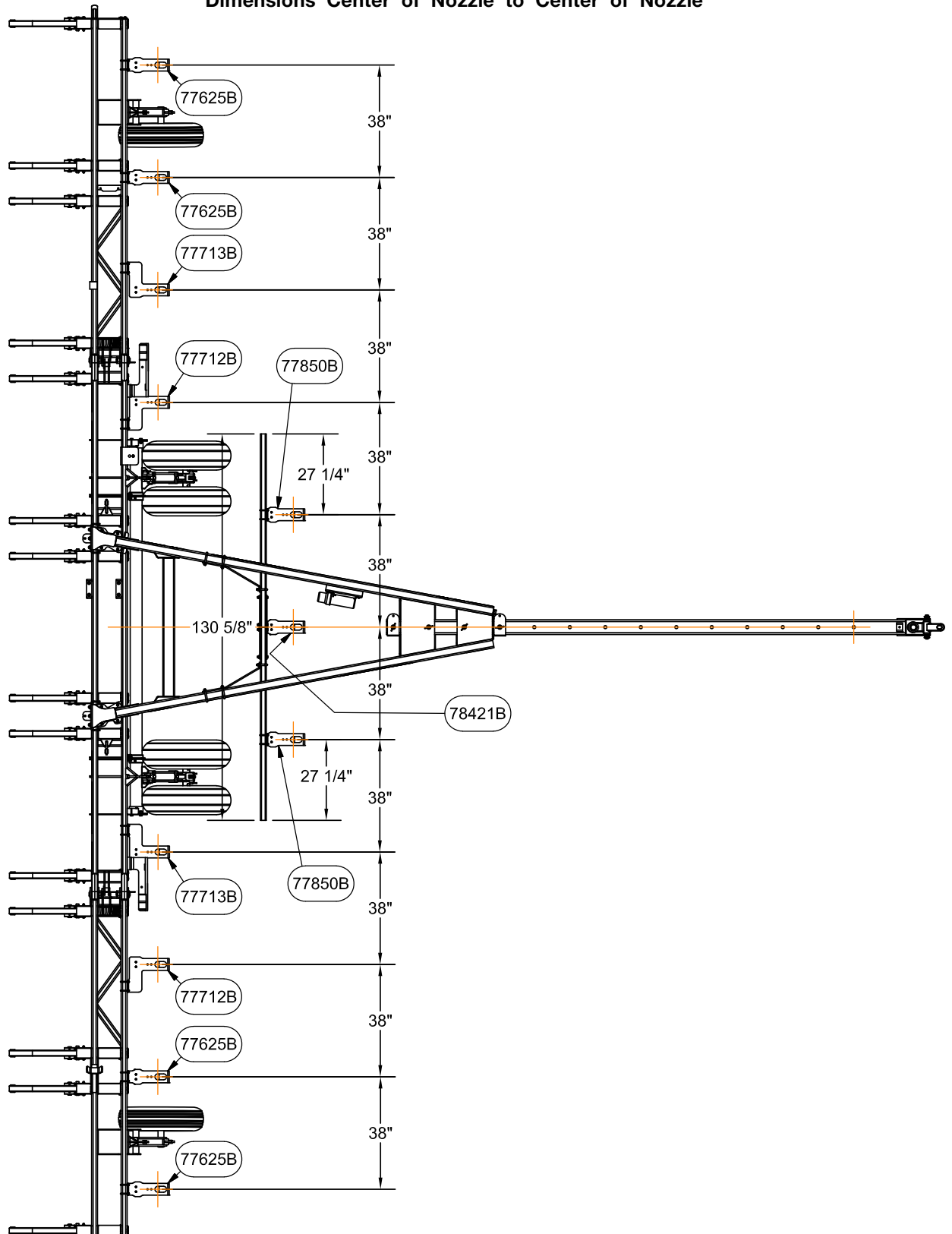

## Overhead Layouts

### 37' Unit with 12 Deflector Nozzles

Dimensions Center of Nozzle to Center of Nozzle

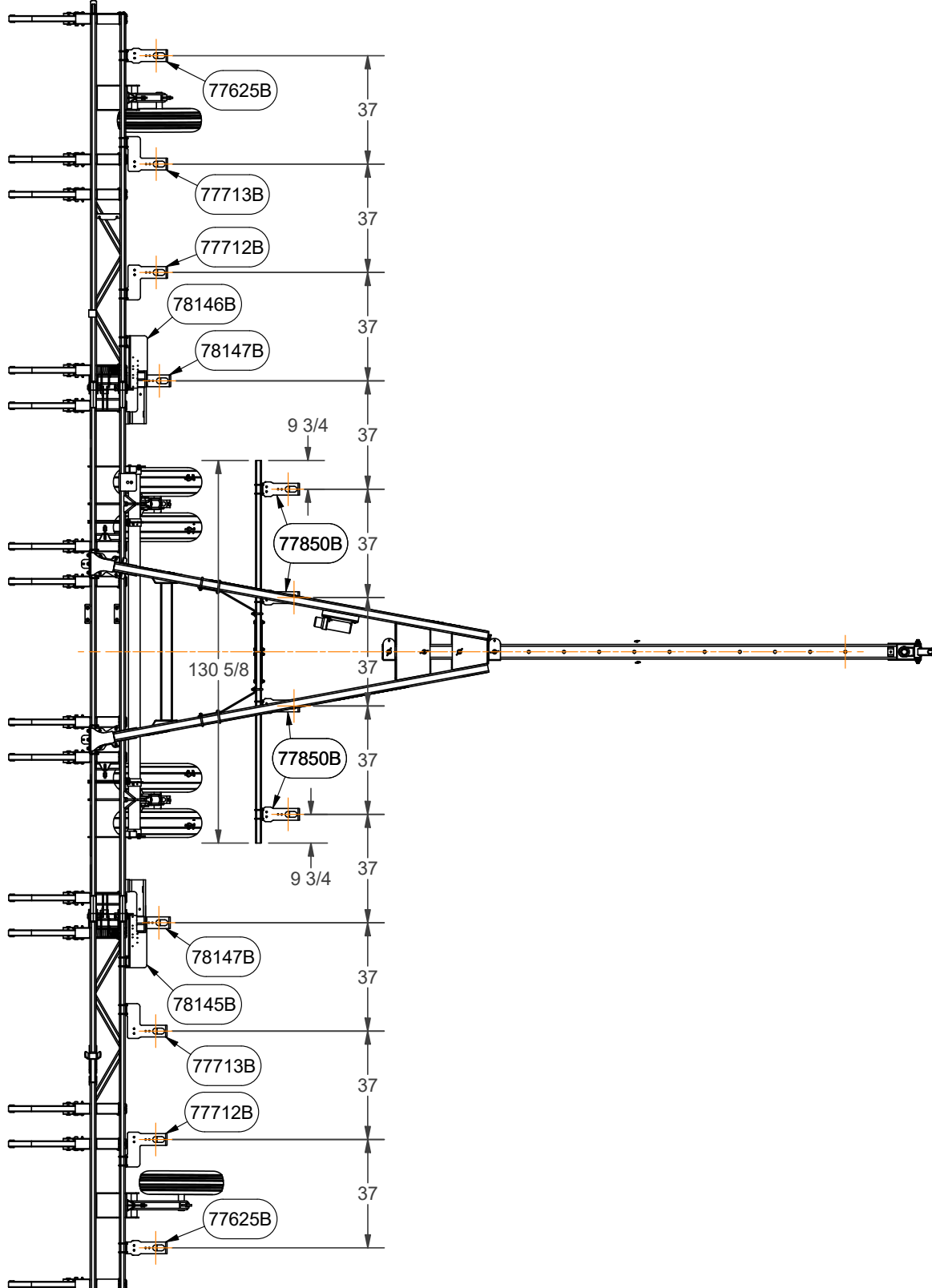

## Raven RCM Guide

### RCM Set-Up

Whenever the tractor is turned off or the ECU for the Cover Crop Seeder loses power, the following steps will have to be performed in order for the RCM to function properly right away.

**NOTE:** Before programming the RCM, ensure the RCM monitor is connected to the battery.

1. On the initial start-up screen, begin by entering the profile name.
2. Select “Generic” as the desired machine type from the drop down menu.
3. Enter the application width of your strip till toolbar.

**NOTE:** Highest value for Application Width is 45 ft.

4. Press the Next Page icon.
5. Default for ECU box and Number of Products is 1. Ensure these both are 1.
6. Press the Next Page icon.





## Raven RCM Guide (continued)

7. Ensure “0” is selected for number of spinner or fan RPM sensors.

8. Press the Next Page icon.



9. Select “Granular Seed (lb)” as the Application Type for Product 1.

10. Press the Next Page icon.



## Raven RCM Guide (continued)

11. Select “Granular Full Width” from the drop down menu for Product 1 Granular Application Mode.
12. Press the Next Page icon.



13. Ensure Equal Width Sections and Granular Product Sections Power to Apply are checked. Also ensure that master clutch is unchecked.
14. Press the Next Page icon.



## Raven RCM Guide (continued)

15. Ensure each box says “None”.

16. Press the Next Page icon.



17. Verify Section setup is correct.

18. Press the Next Page icon.



## Raven RCM Guide (continued)

19. Select “None” from the drop down menu for Scale Setup.

20. Press the Next Page icon.



21. Select “0-138 in/H2O (1-5V)” for Pressure Sensor 1 from the drop down list.

22. Press the Next Page icon.



## Raven RCM Guide (continued)

23. Under Product Sensor 1, ensure there is a checkmark next to Product 1.

24. Press the Next Page icon.



25. For setting the pressure alarm, set the min to “10” and the max to “45” these numbers can be adjusted later once normal operating pressure is determined.

26. Press the Next Page icon.



## Raven RCM Guide (continued)

27. Select “Digital NPN” as the type of sensor for the Height Switch.
28. Press the Next Page icon.



29. For Product 1 Granular, select PWM Close for the control valve type.
30. Enter the desired Valve Response Rate, Control Deadband, and Valve Delay. Make sure Enable PWM Smart Control is unchecked

**NOTE:** The pictured values are generic starting numbers. You can fine tune these values to best fit your application. The white question mark outlines what happens when adjusting each value setting.

31. Press the Next Page icon.



## Raven RCM Guide (continued)

32. Enter “200” for coil frequency, “100” for PWM High Limit, “10” for PWM Low Limit, and “0” for PWM Startup.

33. Press the Next Page icon.



34. Determine the product density of the material to be applied. Enter this value for Product Density. For quick set-up purposes, you can use “46”.

35. Calibration weight depends on the product being applied. Enter “1.007” for a starting theoretical number. This will be calibrated later. Enter “360” for Pulses/Revolution.

36. Press the Next Page icon.





## Raven RCM Guide (continued)

37. Tank Capacity depends on product density. For testing purposes, entering “5000” is recommended.

38. Low Tank Level is the value an alarm is set off for a low bin level. Recommended setting is “100” and ensure the Alarm box is checked. Ensure the Low Bin Level Sensor box is checked and the Mid Bin Level Sensor is unchecked. Select “Default” for Bin Level Sensor Type.

39. Press the Next Page Icon.



40. “Setup Rates” page determines the application rate. Enter three Preset Rate Values, as desired, which can be clicked between on the home screen. On the home screen, target rates can be changed as well.

41. Enter Rate Bump value in an increment as desired.

42. For Rate Selection, select “Predefined or Rx”. This enables selection of rate from the preset value choices or from a prescription map that is imported from a Universal Terminal.

43. Check Display Smoothing and select “0” for Decimal Shift.



## Raven RCM Guide (continued)

44. Press the Next Page icon.
45. Enter 20 for Off Rate Alarm and check Alarm? box.

**NOTE:** Alarm prompts when over 20% off target rate.

46. Press the Next Page icon.



47. No action required on this screen. Shows the setup summary. Make sure all the values are correct.
48. Press the Next Page icon to finish the RCM set-up



## Non ISO-BUS/Variable Rate Controller Guide

This controller includes a RUN/HOLD switch, AUTO/MAN switch, rotary dial/potentiometer, LCD for RPM Feedback, two red / green LED's and a single red LED indicator.

### Console Modes

#### Auto Mode

Console will ignore the user installed footswitch. The only thing that can alter the **RUN/HOLD** state is the switch on the console or the implement switch. If either of these is in **HOLD**, the system will not run.

#### Manual Mode

Console will ignore the implement switch but will look at both the footswitch and console switch. Both the footswitch and console on/off switch must be in the **RUN** position for the system to **RUN**. If either of these is in **HOLD**, the system will not run.

The “Manual” motor controllers provide speed control of 12 VDC motors via a PWM drive that varies in response to input from a manually operated potentiometer.



### Switches

#### Auto / Manual Switch

This switch changes the mode that the console runs in.

#### Run / Hold Switch

When in **RUN**, the system will operate. When switched to **HOLD**, the system will stop. **HOLD** displays on the LCD on the right-hand side when the switch is OFF. The Motor Driver LED will flash at a 1 Hz rate if the switch is in **HOLD**. When the switch returns to **RUN**, the LED will stay on and the console will resume normal operation and indicate shaft RPM on the LCD.



## Non ISO-BUS/Variable Rate Controller Guide (continued)

### LCD Display

The LCD Display's primary objective is to display the seedmeter shaft RPM.

The LCD will indicate if the system is in HOLD via any of the run / hold inputs by displaying HOLD on the right-hand side of the display. LCD also indicates Manual or Auto control of the seed meter as well when the Seed Meter manually is on HOLD. Upon startup of the console, the display will go through a startup process displaying the software revision. Once the software revision has been displayed, the console will be ready for use. LoPwr indicates Low voltage. Check your 12v supply to the console.

LoW rPM indicates low seed meter shaft RPM.



### Inputs / Outputs

#### Power Input

It is recommended to connect to the power on the tractor. If the tractor is ON and console is plugged in, the console is on. There is no power switch on a Non ISO-Bus Controller. 12 Volt input power.

#### Run / Hold Input

##### Foot Switch

The foot switch must be installed for the system to operate. The foot switch turns the Seed Meter on and off. The console MAN/AUTO switch must be in the MAN position and the HOLD/RUN switch must be in the RUN position. When the console switches are in the Auto or HOLD position the footswitch is disabled.

##### Implement Switch

The implement switch allows the system to run in AUTO. When the console switches are in the Auto and Run positions, the implement switch turns the seed meter motor on when the seeder is lowered and sends the system to HOLD if the seeder is lifted. When in MANUAL, the system ignores any signal sent from this switch.

## Non ISO-BUS/Variable Rate Controller Guide (continued)

### Inputs / Outputs (continued)

#### Bin Level LED

Bin Level LED light indicates volume of seed in the Tank.

Green LED indicates adequate seed level above the seed level switch in the tank.

Red LED indicates low seed level.



#### Fan Pressure LED

Fan Pressure LED light indicates if desired air pressure is maintained.

Green LED indicates fan air pressure is at or above the pre-set air pressure switch.

Red LED indicates fan air pressure is below the pre-set air pressure switch.

**NOTE:** Fan air pressure switch can be adjusted to desired level depending on type of seed nozzle spacing. See SET UP section.



#### Motor Driver LED

Motor Driver LED indicates if shaft rotation is sensed.

Green indicates shaft is rotating.

Red indicates shaft is not rotating.

Red Flashing indicates hold status.

Causes of no rotation: Shaft is not turning, Overcurrent indicating too much resistance on the shaft due to something preventing the shaft from turning, bad shaft encoder, open circuit in the wiring.



### Non ISO-BUS/Variable Rate Controller Guide (continued)

#### Inputs / Outputs (continued)

##### Encoder / Shaft Speed Sensor

The Encoder has 9-16 VDC operating voltage and 360 pulses per revolution.

##### Alarm / Buzzer Output

The console must be in RUN for any of the following alarm conditions to sound. If either the Fan Pressure LED or Bin Level LED turns Red, the alarm will signal three short beeps (this sequence happens once).

While in the RUN mode if the RPM drops to 0 the Alarm will sound for 1 second.

#### Low Voltage Detection

When the system supply voltage drops out (~7 VDC) the micro will shut down and the LED will turn off until system voltage returns.

#### Message / Warnings

The LED on steadily will indicate that the console is ON and operating normally. If in HOLD, the LED will flash with a 50 % duty cycle at a 0.833 Hz rate. If a fault condition is indicated, a repeating pattern of blinks and a pause will be shown over a 2.4 second period. Each blink is 100 ms on followed by a 300 ms off period. An Open Load fault is indicated by a single blink within the 2.4 second period, a Shorted Load two blinks followed by a pause and an Over Current condition is three blinks followed by a pause.



## Non ISO-BUS/Variable Rate Controller Guide (continued)

### Special Cal / Defaults

The **CAL** button can be used to change the Pulses per revolution of the shaft and to turn the Audible alarm off.

To enter the **CAL** function the **HOLD/RUN** switch must be in the **HOLD** position. Hold the **CAL** button for 3 seconds. To change the pages press and release the **CAL** button.

**NOTE:** Value should not be changed unless a different shaft encoder is used with a different pulse/REV.



Page 1 = Pulses per Revolution calibration.

Page 2 = Audible Alarm on / off. To change these values, rotate the potentiometer. Values 1-5 = Audible alarm OFF. Values 6-10 Audible Alarm ON. The factory defaults for the cal values are below.

**NOTE:** To save any changes, HOLD **CAL** button for 3 seconds.

**NOTE:** If power is lost before changes are saved, the console will not store any changes.

The factory defaults for the cal values are below. Once these values are changed and CAL is exited, they are saved. There is no way to restore factory defaults.

CAL PAGE	SETTING	DEFAULT VALUE
1	Pulses Per Revolution	360
2	Audible Alarm ON/OFF	ON

## Cover Crop Seeder — Set Up

### Notes



## SECTION III

# Operation

General Operation Information .....	3-2
Preparing Tractor.....	3-2
Preparing Cover Crop Seeder .....	3-3
Bolts and Nuts .....	3-3
Pins.....	3-3
Hydraulics .....	3-3
Operating Instructions .....	3-4
Preparing Seed Meter .....	3-6
Raise The Implement .....	3-6
Nozzle Seed Rate Chart .....	3-8
RAVEN RCM - Catch Test Calibration Procedure.....	3-13
Variable Rate - Catch Test Calibration Procedure .....	3-16

### General Operation Information

#### **WARNING**

- **READ AND UNDERSTAND SAFETY RULES BEFORE OPERATING OR SERVICING THIS MACHINE. REVIEW "SAFETY" SECTION IN THIS MANUAL IF NECESSARY.**

Read this operation section thoroughly. Acquaint yourself with the adjustments required to obtain efficient and trouble-free operations.

### Preparing Tractor

Follow these recommendations if the Cover Crop Seeder will be connected directly to a tractor.

Before operating implement refer to tractor operator's manual for information concerning safe methods of operation, hydraulics, hitch adjustment, tire inflation, wheel adjustments, and tractor weights.

Check tractor brakes and transport lights. Make sure they are in proper working order.

Check tractor hydraulic oil reservoir and add oil if needed.

Tractor must have a minimum of 15 GPM and 2200 PSI hydraulic system to power the Cover Crop Seeder fan.

Tractor must have a case drain coupler.

Be sure tractor drawbar has sufficient capacity to operate the Cover Crop Seeder.

Adjust the tractor drawbar vertically so the top side of the bar is approximately 17 inches from the ground, and lock on center line of tractor.

Secure the tractor 3-Point linkage so that it does not swing into the tractor tires or onto the hoses.

## Preparing Cover Crop Seeder

Perform the service checks as outlined below. Repair or replace any damaged or worn parts before operating.

### Bolts And Nuts

Before going to the field, check all hardware for tightness. Recheck all bolts for tightness, after the unit has been operated for several hours.

### Pins

Before going to the field, check that all pins are in place and are in good condition. Replace any worn, damaged, or missing pins.

Check that locking hardware for pins are in place and tight.

### Hydraulics

#### **IMPORTANT**

- *A zero pressure case drain must be used with the seeder or damage to the fan motor will occur.*

Supply hoses to the seeder must be the same size or larger than the hoses supplied with the Cover Crop Seeder.

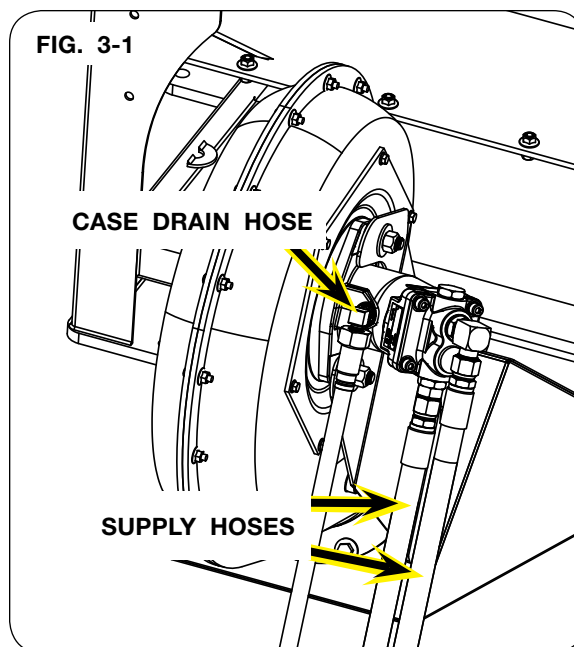

Check routing of all hydraulic hoses. Hoses should not be kinked, twisted, or rubbing against sharp edges. Hoses should be secure with tie straps.

Check hoses and fittings for hydraulic leaks. Tighten or replace as required.

## Operating Instructions

**NOTE:** These instructions apply anytime you don't know what the tractor flow setting must be for proper operation of the seeder. If you know the tractor flow setting you can skip to step 13.

### IMPORTANT

- *Verify that all safety shields are in place and properly secured.*
1. Park the unit on a firm level surface. Block the tires on the unit to prevent it from moving. Set the tractor parking brake.
  2. Make sure the seed cup doors are closed.

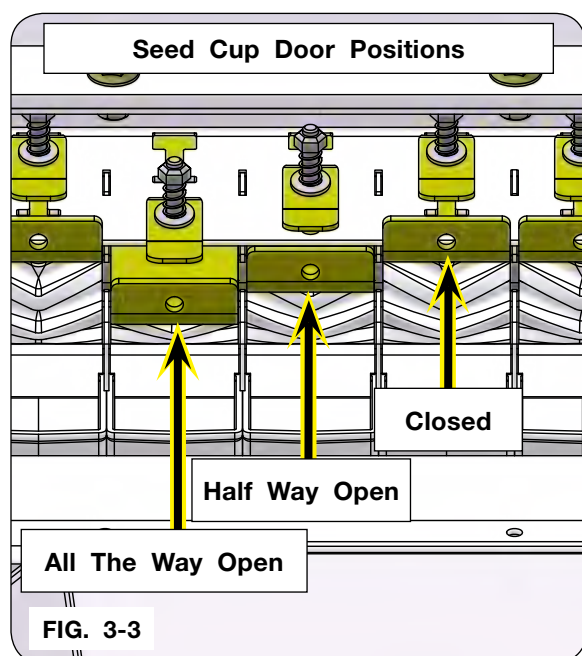
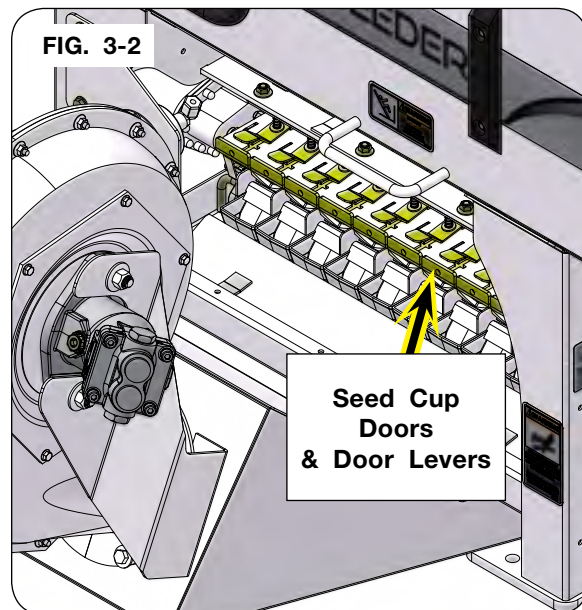

### Operating Instructions (continued)

4. With all shields and door closed, activate the hydraulic SCV for the Cover Crop Seeder.
5. If tractor is equipped with adjustable flow control, lower the flow to its lowest level. Set tractor throttle to expected operating RPM in the field.
6. Operate the tractor until hydraulic fluid comes up to operating temperature.
7. Engage hydraulics and increase SCV flow until 30-32 inches of water is reached on the pressure gauge on the front of the cover crop seeder.

### IMPORTANT

- When turning fan off, always place tractor SCV into **FLOAT**. Failure to do so will damage motor seals or other hydraulic components.
8. Turn SCV off by placing hydraulics in **FLOAT**.

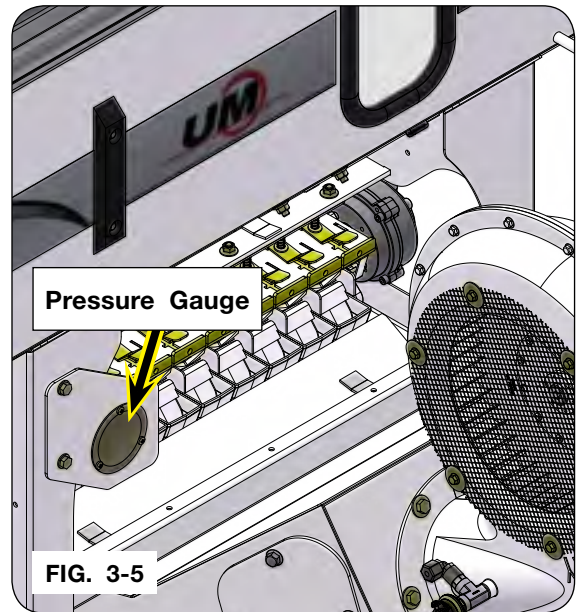

## Operating Instructions (continued)

### Preparing Seed Meter

1. Remove the seed meter shield. (FIG. 3-6)
2. Use the door levers and open seed cup doors half way. (FIG. 3-7)

**NOTE:** Some seed meter cups will not be used. Shut the seed doors on the un-used seed meter cups.

3. Install seed meter shield. (FIG. 3-6)
4. Fill the tank with seed.

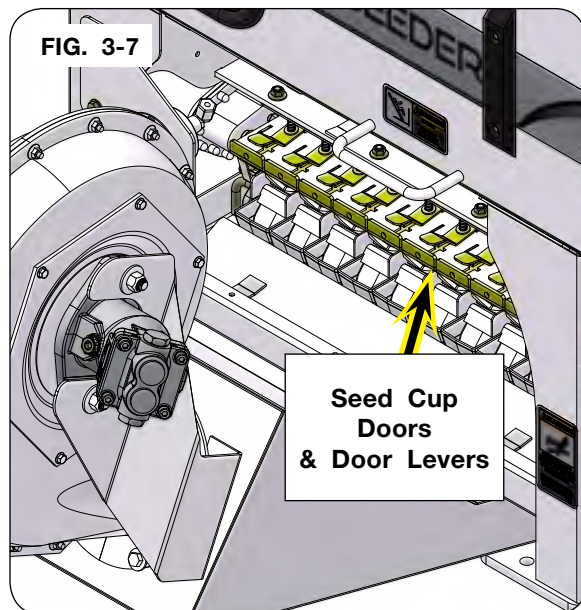
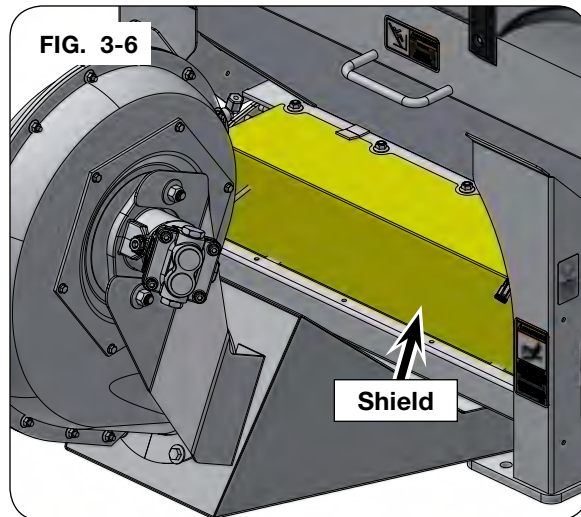

### Raise The Implement

#### IMPORTANT

- When turning fan off, always place tractor SCV into **FLOAT**. Failure to do so will damage motor seals.

You are now ready to seed. Engage the SCV on the tractor and bring the engine up to speed and verify your air pressure.

## Cover Crop Seeder — Nozzle Seed Rate Chart

Minimum of 20-22 inches of water. Recommended operating pressure is 30-32 inches.

40.5 Cu. Ft. = 32 Bushel = 1800 Lbs. of Cereal Rye

**NOTE:** These charts are based on Cereal Rye - Other types of seeds may deviate from the settings on this chart. It is recommended to follow the Calibration procedure for all seeds.

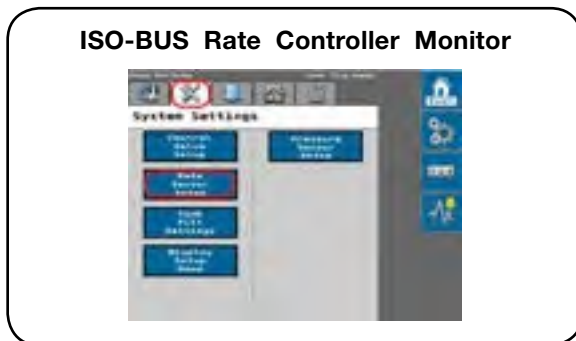
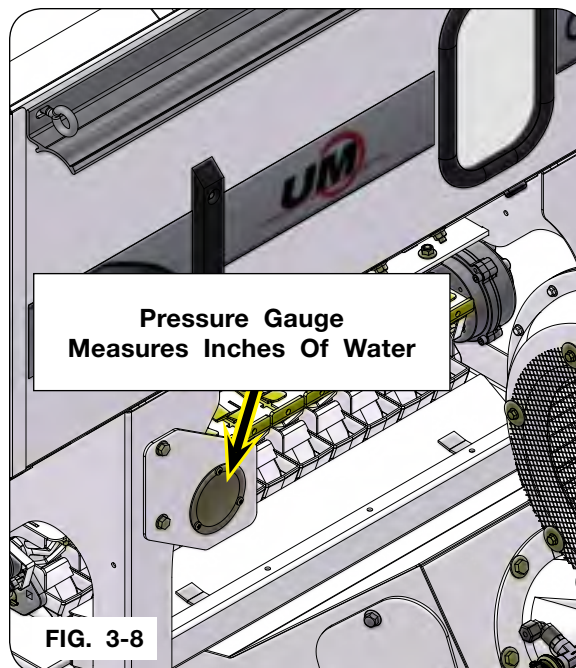

### 18' Unit with 6 Deflector Nozzles

Controller Setting	Lbs in 1 Minute	RATE: LBS. Per Acre								Lbs. of Seed, Per Hose, Per Minute
		Ground Speed (MPH)								
		5	6	7	8	9	10	11	12	
2	1.26	6.9	5.8	5.0	4.3	3.9	3.5	3.2	2.9	0.2
3	4.74	26.1	21.7	18.6	16.3	14.5	13.0	11.9	10.9	0.8
4	9	49.5	41.3	35.4	30.9	27.5	24.8	22.5	20.6	1.5
5	11.58	63.7	53.1	45.5	39.8	35.4	31.8	29.0	26.5	1.9
6	13.2	72.6	60.5	51.9	45.4	40.3	36.3	33.0	30.3	2.2
7	14.46	79.5	66.3	56.8	49.7	44.2	39.8	36.2	33.1	2.4
8	15.06	82.8	69.0	59.2	51.8	46.0	41.4	37.7	34.5	2.5
9	15.66	86.1	71.8	61.5	53.8	47.9	43.1	39.2	35.9	2.6
10	15.84	87.1	72.6	62.2	54.5	48.4	43.6	39.6	36.3	2.6



# Cover Crop Seeder — Operation

## Cover Crop Seeder — Nozzle Seed Rate Chart

### 20' Unit with 6 Deflector Nozzles

Controller Setting	Lbs in 1 Minute	RATE: LBS. Per Acre								Lbs. of Seed, Per Hose, Per Minute
		Ground Speed (MPH)								
		5	6	7	8	9	10	11	12	
2	1.26	6.2	5.2	4.5	3.9	3.5	3.1	2.8	2.6	0.2
3	4.74	23.5	19.6	16.8	14.7	13.0	11.7	10.7	9.8	0.8
4	9	44.6	37.1	31.8	27.8	24.8	22.3	20.3	18.6	1.5
5	11.58	57.3	47.8	40.9	35.8	31.8	28.7	26.1	23.9	1.9
6	13.2	65.3	54.5	46.7	40.8	36.3	32.7	29.7	27.2	2.2
7	14.46	71.6	59.7	51.1	44.7	39.8	35.8	32.5	29.8	2.4
8	15.06	74.6	62.1	53.3	46.6	41.4	37.3	33.9	31.1	2.5
9	15.66	77.5	64.6	55.4	48.5	43.1	38.8	35.2	32.3	2.6
10	15.84	78.4	65.3	56.0	49.0	43.6	39.2	35.6	32.7	2.6

### 21' Unit with 6 Deflector Nozzles

Controller Setting	Lbs in 1 Minute	RATE: LBS. Per Acre								Lbs. of Seed, Per Hose, Per Minute
		Ground Speed (MPH)								
		5	6	7	8	9	10	11	12	
2	1.26	5.9	5.0	4.2	3.7	3.3	3.0	2.7	2.5	0.2
3	4.74	22.3	18.6	16.0	14.0	12.4	11.2	10.2	9.3	0.8
4	9	42.4	35.4	30.3	26.5	23.6	21.2	19.3	17.7	1.5
5	11.58	54.6	45.5	39.0	34.1	30.3	27.3	24.8	22.7	1.9
6	13.2	62.2	51.9	44.5	38.9	34.6	31.1	28.3	25.9	2.2
7	14.46	68.2	56.8	48.7	42.6	37.9	34.1	31.0	28.4	2.4
8	15.06	71.0	59.2	50.7	44.4	39.4	35.5	32.3	29.6	2.5
9	15.66	73.8	61.5	52.7	46.1	41.0	36.9	33.6	30.8	2.6
10	15.84	74.7	62.2	53.3	46.7	41.5	37.3	33.9	31.1	2.6

### 22' Unit with 7 Deflector Nozzles

Controller Setting	Lbs in 1 Minute	RATE: LBS. Per Acre								Lbs. of Seed, Per Hose, Per Minute
		Ground Speed (MPH)								
		5	6	7	8	9	10	11	12	
2	1.47	6.6	5.5	4.7	4.1	3.7	3.3	3.0	2.8	0.2
3	5.53	24.9	20.7	17.8	15.6	13.8	12.4	11.3	10.4	0.8
4	10.5	47.3	39.4	33.8	29.5	26.3	23.6	21.5	19.7	1.5
5	13.51	60.8	50.7	43.4	38.0	33.8	30.4	27.6	25.3	1.9
6	15.4	69.3	57.8	49.5	43.3	38.5	34.7	31.5	28.9	2.2
7	16.87	75.9	63.3	54.2	47.5	42.2	38.0	34.5	31.6	2.4
8	17.57	79.1	65.9	56.5	49.4	43.9	39.5	35.9	32.9	2.5
9	18.27	82.2	68.5	58.7	51.4	45.7	41.1	37.4	34.3	2.6
10	18.48	83.2	69.3	59.4	52.0	46.2	41.6	37.8	34.7	2.6



## Cover Crop Seeder — Nozzle Seed Rate Chart

### 23' Unit with 7 Deflector Nozzles

Controller Setting	Lbs in 1 Minute	RATE: LBS. Per Acre								Lbs. of Seed, Per Hose, Per Minute
		Ground Speed (MPH)								
		5	6	7	8	9	10	11	12	
2	1.47	6.3	5.3	4.5	4.0	3.5	3.2	2.9	2.6	0.2
3	5.53	23.8	19.8	17.0	14.9	13.2	11.9	10.8	9.9	0.8
4	10.5	45.2	37.7	32.3	28.3	25.1	22.6	20.5	18.8	1.5
5	13.51	58.2	48.5	41.5	36.3	32.3	29.1	26.4	24.2	1.9
6	15.4	66.3	55.2	47.4	41.4	36.8	33.1	30.1	27.6	2.2
7	16.87	72.6	60.5	51.9	45.4	40.3	36.3	33.0	30.3	2.4
8	17.57	75.6	63.0	54.0	47.3	42.0	37.8	34.4	31.5	2.5
9	18.27	78.6	65.5	56.2	49.2	43.7	39.3	35.7	32.8	2.6
10	18.48	79.6	66.3	56.8	49.7	44.2	39.8	36.2	33.1	2.6

### 24' Unit with 7 Deflector Nozzles

Controller Setting	Lbs in 1 Minute	RATE: LBS. Per Acre								Lbs. of Seed, Per Hose, Per Minute
		Ground Speed (MPH)								
		5	6	7	8	9	10	11	12	
2	1.47	6.1	5.1	4.3	3.8	3.4	3.0	2.8	2.5	0.2
3	5.53	22.8	19.0	16.3	14.3	12.7	11.4	10.4	9.5	0.8
4	10.5	43.3	36.1	30.9	27.1	24.1	21.7	19.7	18.0	1.5
5	13.51	55.7	46.4	39.8	34.8	31.0	27.9	25.3	23.2	1.9
6	15.4	63.5	52.9	45.4	39.7	35.3	31.8	28.9	26.5	2.2
7	16.87	69.6	58.0	49.7	43.5	38.7	34.8	31.6	29.0	2.4
8	17.57	72.5	60.4	51.8	45.3	40.3	36.2	32.9	30.2	2.5
9	18.27	75.4	62.8	53.8	47.1	41.9	37.7	34.3	31.4	2.6
10	18.48	76.2	63.5	54.5	47.6	42.4	38.1	34.7	31.8	2.6

### 25' Unit with 8 Deflector Nozzles

Controller Setting	Lbs in 1 Minute	RATE: LBS. Per Acre								Lbs. of Seed, Per Hose, Per Minute
		Ground Speed (MPH)								
		5	6	7	8	9	10	11	12	
2	1.68	6.7	5.5	4.8	4.2	3.7	3.3	3.0	2.8	0.2
3	6.32	25.0	20.9	17.9	15.6	13.9	12.5	11.4	10.4	0.8
4	12	47.5	39.6	33.9	29.7	26.4	23.8	21.6	19.8	1.5
5	15.44	61.1	51.0	43.7	38.2	34.0	30.6	27.8	25.5	1.9
6	17.6	69.7	58.1	49.8	43.6	38.7	34.9	31.7	29.0	2.2
7	19.28	76.4	63.6	54.5	47.7	42.4	38.2	34.7	31.8	2.4
8	20.08	79.5	66.3	56.8	49.7	44.2	39.8	36.1	33.1	2.5
9	20.88	82.7	68.9	59.1	51.7	45.9	41.3	37.6	34.5	2.6
10	21.12	83.6	69.7	59.7	52.3	46.5	41.8	38.0	34.9	2.6

## Cover Crop Seeder — Nozzle Seed Rate Chart

### 26' Unit with 8 Deflector Nozzles

Controller Setting	Lbs in 1 Minute	RATE: LBS. Per Acre								Lbs. of Seed, Per Hose, Per Minute
		Ground Speed (MPH)								
		5	6	7	8	9	10	11	12	
2	1.68	6.4	5.3	4.6	4.0	3.6	3.2	2.9	2.7	0.2
3	6.32	24.1	20.1	17.2	15.0	13.4	12.0	10.9	10.0	0.8
4	12	45.7	38.1	32.6	28.6	25.4	22.8	20.8	19.0	1.5
5	15.44	58.8	49.0	42.0	36.7	32.7	29.4	26.7	24.5	1.9
6	17.6	67.0	55.9	47.9	41.9	37.2	33.5	30.5	27.9	2.2
7	19.28	73.4	61.2	52.4	45.9	40.8	36.7	33.4	30.6	2.4
8	20.08	76.5	63.7	54.6	47.8	42.5	38.2	34.8	31.9	2.5
9	20.88	79.5	66.3	56.8	49.7	44.2	39.8	36.1	33.1	2.6
10	21.12	80.4	67.0	57.4	50.3	44.7	40.2	36.6	33.5	2.6

### 27' Unit with 8 Deflector Nozzles

Controller Setting	Lbs in 1 Minute	RATE: LBS. Per Acre								Lbs. of Seed, Per Hose, Per Minute
		Ground Speed (MPH)								
		5	6	7	8	9	10	11	12	
2	1.68	6.2	5.1	4.4	3.9	3.4	3.1	2.8	2.6	0.2
3	6.32	23.2	19.3	16.6	14.5	12.9	11.6	10.5	9.7	0.8
4	12	44.0	36.7	31.4	27.5	24.4	22.0	20.0	18.3	1.5
5	15.44	56.6	47.2	40.4	35.4	31.5	28.3	25.7	23.6	1.9
6	17.6	64.5	53.8	46.1	40.3	35.9	32.3	29.3	26.9	2.2
7	19.28	70.7	58.9	50.5	44.2	39.3	35.4	32.1	29.5	2.4
8	20.08	73.6	61.4	52.6	46.0	40.9	36.8	33.5	30.7	2.5
9	20.88	76.6	63.8	54.7	47.9	42.5	38.3	34.8	31.9	2.6
10	21.12	77.4	64.5	55.3	48.4	43.0	38.7	35.2	32.3	2.6

### 28' Unit with 8 Deflector Nozzles

Controller Setting	Lbs in 1 Minute	RATE: LBS. Per Acre								Lbs. of Seed, Per Hose, Per Minute
		Ground Speed (MPH)								
		5	6	7	8	9	10	11	12	
2	1.68	5.9	5.0	4.2	3.7	3.3	3.0	2.7	2.5	0.2
3	6.32	22.3	18.6	16.0	14.0	12.4	11.2	10.2	9.3	0.8
4	12	42.4	35.4	30.3	26.5	23.6	21.2	19.3	17.7	1.5
5	15.44	54.6	45.5	39.0	34.1	30.3	27.3	24.8	22.7	1.9
6	17.6	62.2	51.9	44.5	38.9	34.6	31.1	28.3	25.9	2.2
7	19.28	68.2	56.8	48.7	42.6	37.9	34.1	31.0	28.4	2.4
8	20.08	71.0	59.2	50.7	44.4	39.4	35.5	32.3	29.6	2.5
9	20.88	73.8	61.5	52.7	46.1	41.0	36.9	33.6	30.8	2.6
10	21.12	74.7	62.2	53.3	46.7	41.5	37.3	33.9	31.1	2.6

# Cover Crop Seeder — Operation

## Cover Crop Seeder — Nozzle Seed Rate Chart

### 29' Unit with 9 Deflector Nozzles

Controller Setting	Lbs in 1 Minute	RATE: LBS. Per Acre								Lbs. of Seed, Per Hose, Per Minute
		Ground Speed (MPH)								
		5	6	7	8	9	10	11	12	
2	1.89	6.5	5.4	4.6	4.0	3.6	3.2	2.9	2.7	0.2
3	7.11	24.3	20.2	17.3	15.2	13.5	12.1	11.0	10.1	0.8
4	13.5	46.1	38.4	32.9	28.8	25.6	23.0	21.0	19.2	1.5
5	17.37	59.3	49.4	42.4	37.1	32.9	29.7	27.0	24.7	1.9
6	19.8	67.6	56.3	48.3	42.2	37.6	33.8	30.7	28.2	2.2
7	21.69	74.1	61.7	52.9	46.3	41.1	37.0	33.7	30.9	2.4
8	22.59	77.1	64.3	55.1	48.2	42.8	38.6	35.1	32.1	2.5
9	23.49	80.2	66.8	57.3	50.1	44.6	40.1	36.5	33.4	2.6
10	23.76	81.1	67.6	57.9	50.7	45.1	40.6	36.9	33.8	2.6

### 30' Unit with 9 Deflector Nozzles

Controller Setting	Lbs in 1 Minute	RATE: LBS. Per Acre								Lbs. of Seed, Per Hose, Per Minute
		Ground Speed (MPH)								
		5	6	7	8	9	10	11	12	
2	1.89	6.2	5.2	4.5	3.9	3.5	3.1	2.8	2.6	0.2
3	7.11	23.5	19.6	16.8	14.7	13.0	11.7	10.7	9.8	0.8
4	13.5	44.6	37.1	31.8	27.8	24.8	22.3	20.3	18.6	1.5
5	17.37	57.3	47.8	40.9	35.8	31.8	28.7	26.1	23.9	1.9
6	19.8	65.3	54.5	46.7	40.8	36.3	32.7	29.7	27.2	2.2
7	21.69	71.6	59.7	51.1	44.7	39.8	35.8	32.5	29.8	2.4
8	22.59	74.6	62.1	53.3	46.6	41.4	37.3	33.9	31.1	2.5
9	23.49	77.5	64.6	55.4	48.5	43.1	38.8	35.2	32.3	2.6
10	23.76	78.4	65.3	56.0	49.0	43.6	39.2	35.6	32.7	2.6

### 31' Unit with 9 Deflector Nozzles

Controller Setting	Lbs in 1 Minute	RATE: LBS. Per Acre								Lbs. of Seed, Per Hose, Per Minute
		Ground Speed (MPH)								
		5	6	7	8	9	10	11	12	
2	1.89	6.0	5.0	4.3	3.8	3.4	3.0	2.7	2.5	0.2
3	7.11	22.7	18.9	16.2	14.2	12.6	11.4	10.3	9.5	0.8
4	13.5	43.1	35.9	30.8	26.9	24.0	21.6	19.6	18.0	1.5
5	17.37	55.5	46.2	39.6	34.7	30.8	27.7	25.2	23.1	1.9
6	19.8	63.2	52.7	45.2	39.5	35.1	31.6	28.7	26.3	2.2
7	21.69	69.3	57.7	49.5	43.3	38.5	34.6	31.5	28.9	2.4
8	22.59	72.1	60.1	51.5	45.1	40.1	36.1	32.8	30.1	2.5
9	23.49	75.0	62.5	53.6	46.9	41.7	37.5	34.1	31.3	2.6
10	23.76	75.9	63.2	54.2	47.4	42.2	37.9	34.5	31.6	2.6

# Cover Crop Seeder — Operation

## Cover Crop Seeder — Nozzle Seed Rate Chart

### 33' Unit with 10 Deflector Nozzles

Controller Setting	Lbs in 1 Minute	RATE: LBS. Per Acre								Lbs. of Seed, Per Hose, Per Minute
		Ground Speed (MPH)								
		5	6	7	8	9	10	11	12	
2	2.1	6.3	5.3	4.5	3.9	3.5	3.2	2.9	2.6	0.2
3	7.9	23.7	19.8	16.9	14.8	13.2	11.9	10.8	9.9	0.8
4	15	45.0	37.5	32.1	28.1	25.0	22.5	20.5	18.8	1.5
5	19.3	57.9	48.3	41.4	36.2	32.2	29.0	26.3	24.1	1.9
6	22	66.0	55.0	47.1	41.3	36.7	33.0	30.0	27.5	2.2
7	24.1	72.3	60.3	51.6	45.2	40.2	36.2	32.9	30.1	2.4
8	25.1	75.3	62.8	53.8	47.1	41.8	37.7	34.2	31.4	2.5
9	26.1	78.3	65.3	55.9	48.9	43.5	39.2	35.6	32.6	2.6
10	26.4	79.2	66.0	56.6	49.5	44.0	39.6	36.0	33.0	2.6

### 35' Unit with 11 Deflector Nozzles

Controller Setting	Lbs in 1 Minute	RATE: LBS. Per Acre								Lbs. of Seed, Per Hose, Per Minute
		Ground Speed (MPH)								
		5	6	7	8	9	10	11	12	
2	2.31	6.5	5.4	4.7	4.1	3.6	3.3	3.0	2.7	0.2
3	8.69	24.6	20.5	17.6	15.4	13.7	12.3	11.2	10.2	0.8
4	16.5	46.7	38.9	33.3	29.2	25.9	23.3	21.2	19.4	1.5
5	21.23	60.1	50.0	42.9	37.5	33.4	30.0	27.3	25.0	1.9
6	24.2	68.5	57.0	48.9	42.8	38.0	34.2	31.1	28.5	2.2
7	26.51	75.0	62.5	53.6	46.9	41.7	37.5	34.1	31.2	2.4
8	27.61	78.1	65.1	55.8	48.8	43.4	39.1	35.5	32.5	2.5
9	28.71	81.2	67.7	58.0	50.8	45.1	40.6	36.9	33.8	2.6
10	29.04	82.1	68.5	58.7	51.3	45.6	41.1	37.3	34.2	2.6

### 37' Unit with 12 Deflector Nozzles

Controller Setting	Lbs in 1 Minute	RATE: LBS. Per Acre								Lbs. of Seed, Per Hose, Per Minute
		Ground Speed (MPH)								
		5	6	7	8	9	10	11	12	
2	2.52	6.7	5.6	4.8	4.2	3.7	3.4	3.1	2.8	0.2
3	9.48	25.4	21.1	18.1	15.9	14.1	12.7	11.5	10.6	0.8
4	18	48.2	40.1	34.4	30.1	26.8	24.1	21.9	20.1	1.5
5	23.16	62.0	51.6	44.3	38.7	34.4	31.0	28.2	25.8	1.9
6	26.4	70.6	58.9	50.5	44.2	39.2	35.3	32.1	29.4	2.2
7	28.92	77.4	64.5	55.3	48.4	43.0	38.7	35.2	32.2	2.4
8	30.12	80.6	67.2	57.6	50.4	44.8	40.3	36.6	33.6	2.5
9	31.32	83.8	69.8	59.9	52.4	46.6	41.9	38.1	34.9	2.6
10	31.68	84.8	70.6	60.6	53.0	47.1	42.4	38.5	35.3	2.6

## Raven RCM - Catch Test Calibration Procedure

A catch test procedure will need to be performed before initial use and every time seed type is changed.

1. Park the unit and block the wheels.
2. Close the seed doors to all but the right most row. (Close all seed doors not getting tested.)
3. Prime the seed meter by running the meter in self-test.
4. Pull the seed cup retaining rod from the left hand side of the machine until the right most seed cup can be removed from under the meter wheel.
5. Place a catch containers under this meter wheel.
6. Back in the tractor, engage the hydraulics after following the hydraulic flow setting procedure.
7. On the virtual terminal, press the settings page icon.



8. Press the Rate Sensor Setup icon.

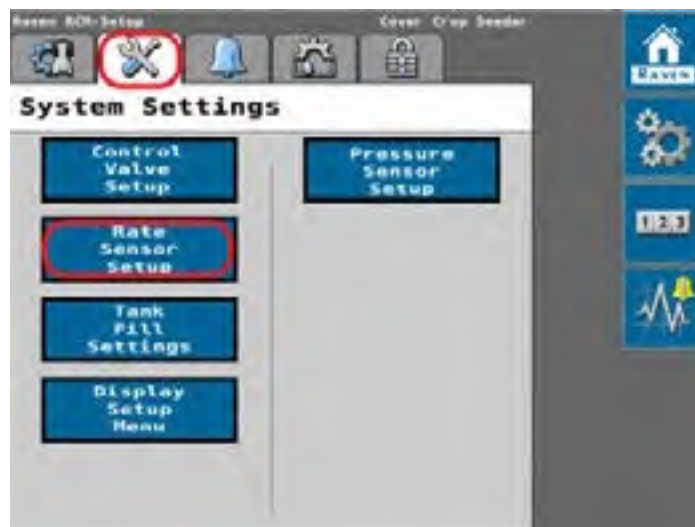

## Raven RCM - Catch Test Calibration Procedure (continued)

9. Press the Catch Test Calibration icon.

**NOTE:** If the Catch Test Calibration icon does not appear in blue, make sure your master switch is off and the test speed is 0.



10. A warning note will pop up saying that movement of the machine will occur. Press the green checkmark to acknowledge.

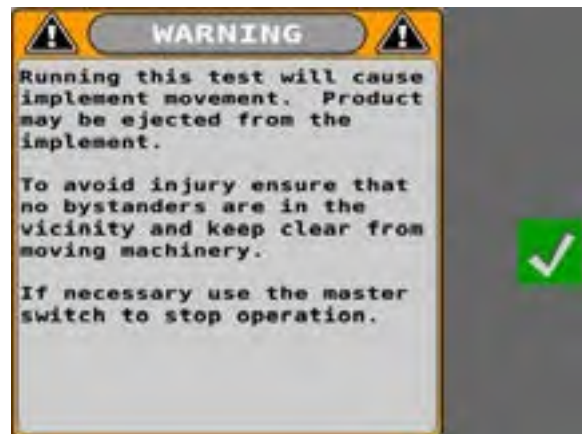

## Raven RCM - Catch Test Calibration Procedure (continued)

11. Enter a test speed that is similar to what will be ran used during in field operation.
12. Enter the application rate that will be used during in field operation.
13. Enter the desired amount of material to be caught.

**NOTE:** The amount of weight collected must be less than the size of your catch containers. For example, If we catch 1 seed cup on a twelve row unit, We would use (catch weight \* 12) as our calibration weight.

Calibration weight = Catch Weight \* (# of active rows on unit / # of rows used to catch)

14. Select the Next Page icon.
15. Turn the master switch on and select Start.
16. After the test is complete, take and weigh the amount of material collected. This total will need to be multiplied by the number of deflectors or output hoses that your configuration is using.
17. Enter this weight into the RCM and select the blue checkmark to complete the catch test calibration.
18. Repeat Steps 7-17 to verify accuracy.





### Variable Rate - Catch Test Calibration Procedure

The Non ISO-BUS/variable rate controller settings will get you in the range of the desired rate and adjusting the ground speed fine tunes that rate.

**NOTE:** It is recommend to perform all calibration procedures with hydraulic oil at operating temperatures.

1. Park the unit on a firm level surface. Block the tires on the unit to prevent it from moving. Set the tractor parking brake.
2. Determine desired operating speed and seeding rate. Refer to the “Seed Rate Chart” to determine the variable rate controller setting.
3. Close the seed cup doors.
4. Load seed into the tank.
5. With tractor running and SCV off, toggle the Cover Crop Seeder switch to on.
6. Adjust the variable rate controller setting found on the “Seed Rate Chart” from Step 2.
7. Remove the hose from a nozzle you want to calibrate.
8. Open the seed cup door half way that corresponds with the hose that was removed from the nozzle in step 7.
9. With tractor in Park engage the SVC that operates the cover seeder and bring the Engine up to speed used in set up.
10. Verify the fan pressure is at 20”-21” of water.

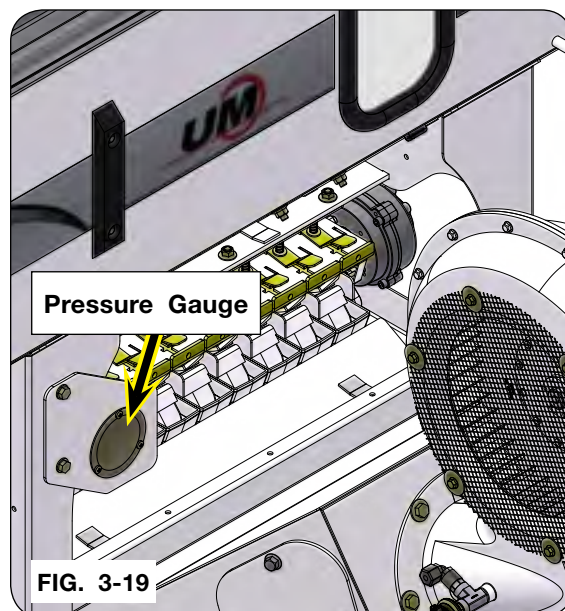



### Variable Rate - Catch Test Calibration Procedure (continued)

11. To prime the seed meter, Adjust the variable rate controller setting briefly until a steady flow of seed is entering the seed cup.
  13. Place a bucket under the hose that was previously removed from a nozzle and place a cloth over the hose and bucket to capture the seed.
  14. Gather seed for exactly 1 minute.
  15. Disengage the SCV by placing the hydraulics in **FLOAT** and measure the pounds of seed in the bucket.
  16. The measurement of seed should closely agree with the “Seed Rate Chart” under the column of “Lbs. of Seed, Per Hose, Per Minute”.
  17. If the amount collected is lower than the “Seed Rate Chart”, you will have to decrease your ground speed slightly when operating in the field or increase the variable rate controller setting. If the amount collected is higher, you will have to increase your ground speed or decrease the variable rate controller setting.
- NOTE:** If the seed your calibrating varies significantly from the “Seed Rate Chart” we recommend calculating your rate using the “Manual Calculation Procedure”.
18. Repeat as necessary.
  19. Upon completion of the calibration, reinstall the hose into the nozzle.
  20. Open all the seed cup doors half way that correspond with a nozzle.

### Manual Calculation Procedure

To Manually Calculate the rate you will need to do the following Calculations:

- A. Multiply the following:  $.00202 \times \text{Machine Width (Ft.)} \times \text{Desired Speed (MPH)} = A$
- B. Multiply:  $\text{LBS collected in 1 minute from 1 nozzle} \times \text{Number of Nozzles} = B$
- C. Divide:  $B \div A = \text{Rate of Seed per Acre}$

**Notes**

# **SECTION IV**

# **Maintenance**

How to Clean Out Seed Meter Assembly ..... 4-2  
How to Clean Out Seed Meter Cups ..... 4-6  
How to Replace Seals in Fan Motor ..... 4-8  
Storage ..... 4-9  
Electrical Schematics ..... 4-10  
Torque Chart ..... 4-19  
Hydraulic Fittings ..... 4-19

## How To Clean Out Seed Meter Assembly

1. Park the unit on a firm level surface. Block the tires on the unit to prevent it from moving. Set the vehicle parking brake, shut off the engine, and remove the ignition key.

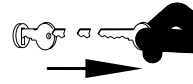

2. Remove the seed meter shield. (FIG. 4-1)

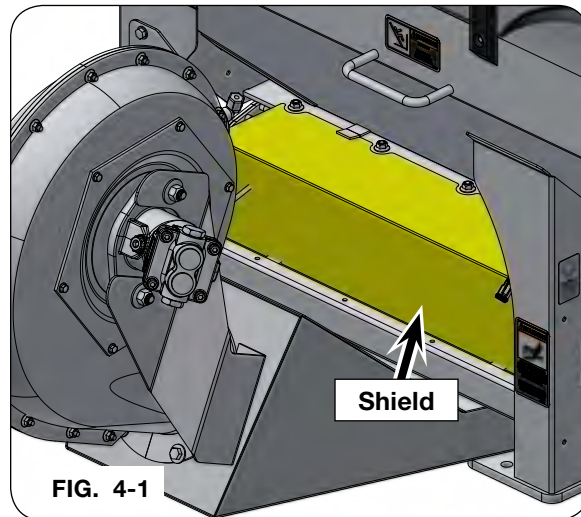

3. Place appropriate container under cover seeder. Open the Seed meter door, then unlatch the door to allow seed to exit the cover crop seeder. Repeat with second door.

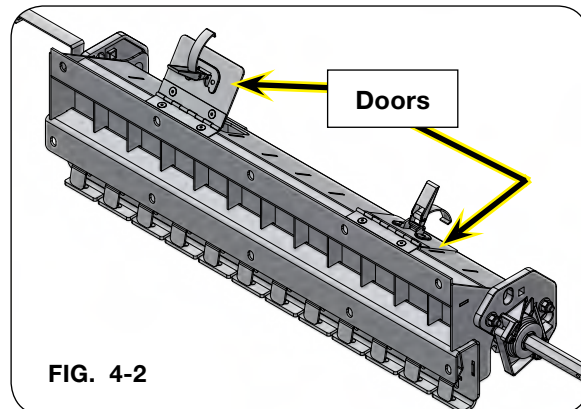

4. Remove the klik-pin from the shaft on the motor side. (FIG. 4-3)

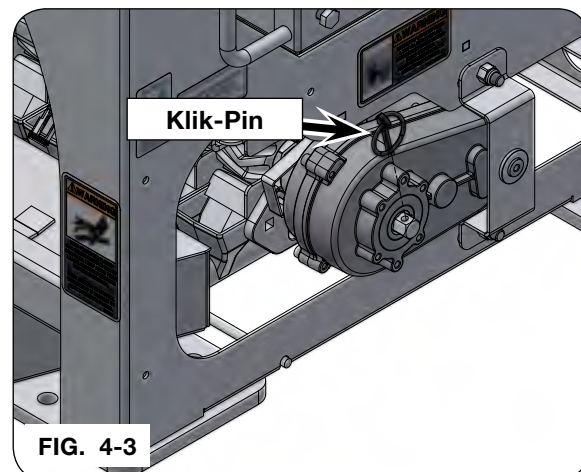

## How To Clean Out Seed Meter Assembly (continued)

5. Disconnect the encoder from the baseline harness. (FIG. 4-4)
6. Remove the hairpin cotter. (FIG. 4-4)

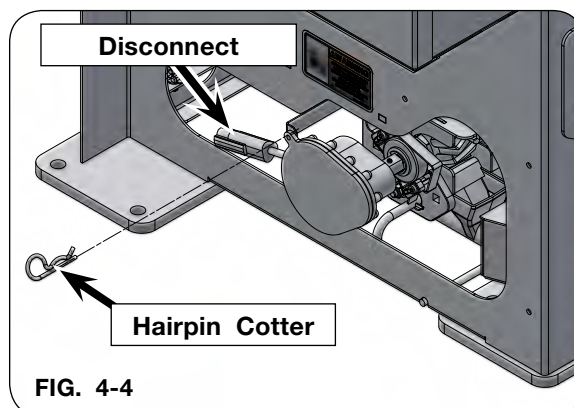

7. Slide shaft and encoder out of the seed meter house just enough to clear the motor.
8. Unlatch the bearing clips (1 per end of the meter housing).

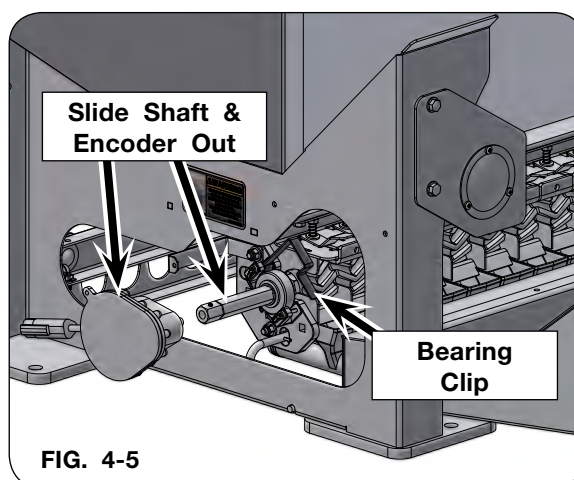

9. Entire shaft, meters wheels and bearings can be removed from the seed meter housing in the direction towards the fan. Once clear of the meter housing the entire shaft roller assembly can be removed from the encoder side of the seeder.
10. Clean out the seed meter assembly.
11. Reinstall meter shaft with seed meter wheels and bearings installed on the shaft. It works best to start on 1 end and slide 1st bearing in place and slide 1st seed meter wheel into the 1st opening repeat moving down the shaft until all meters enter the appropriate opening.

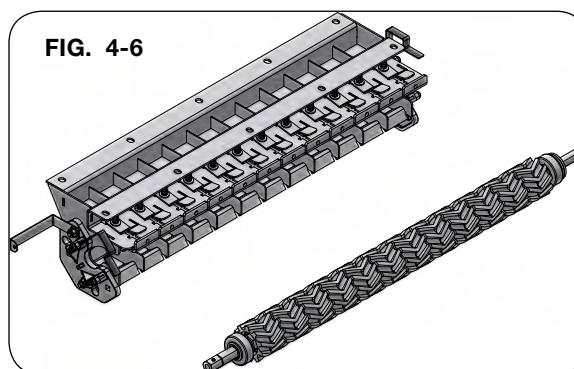

## How To Clean Out Seed Meter Assembly (continued)

12. Latch the bearing clips (1 per end of the meter housing).
13. Install shaft and encoder into the seed meter housing and the motor.

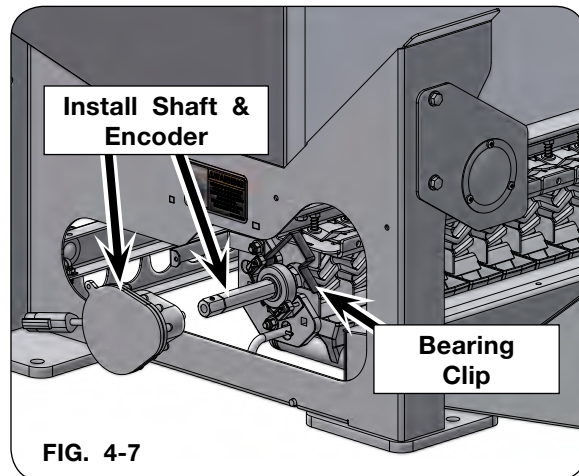

14. Attach the hairpin cotter.
15. Connect the encoder to the baseline harness.

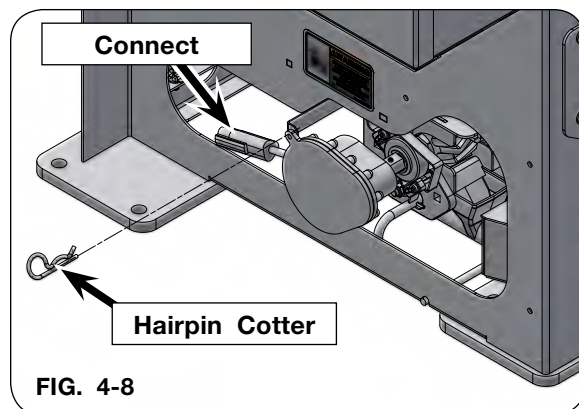

16. Install the klik-pin into the shaft on the motor side. (FIG. 4-9)

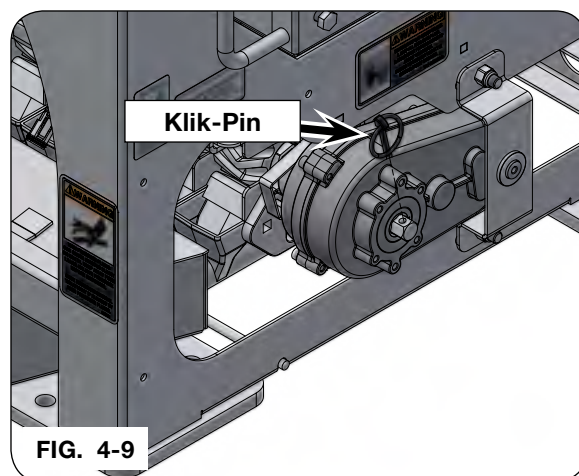

**How To Clean Out Seed Meter Assembly (continued)**

- 17. Latch both rear doors (78423B).  
(FIG. 4-10)

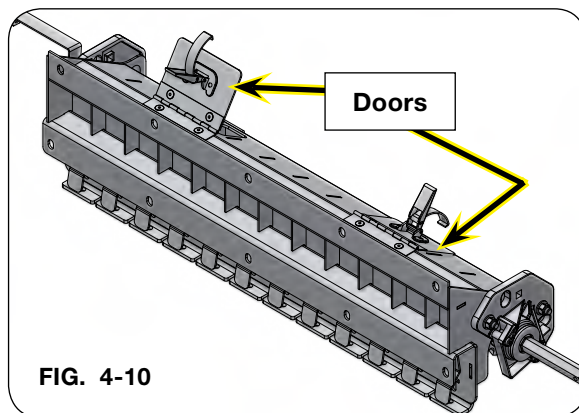

- 18. Install the seed meter shield. (FIG. 4-11)

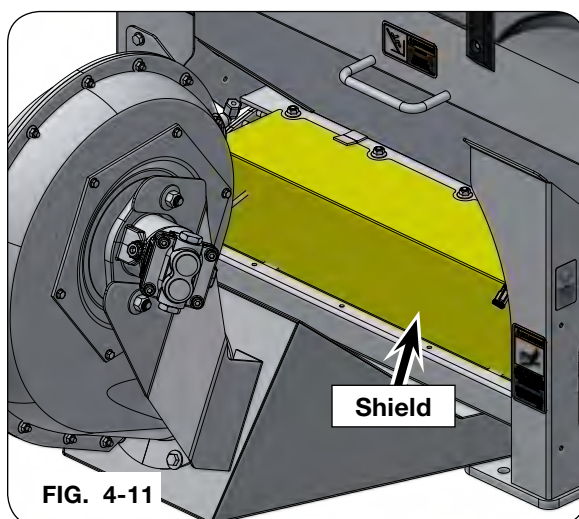



## How To Clean Out Seed Meter Cups

1. Park the unit on a firm level surface. Block the tires on the unit to prevent it from moving. Set the vehicle parking brake, shut off the engine, and remove the ignition key.
2. Twist the rod/roll pin assembly counter clockwise 90 degrees.

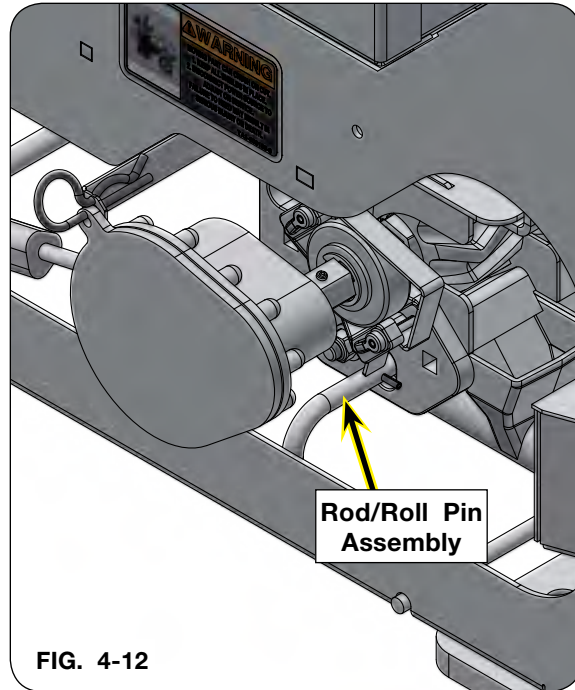
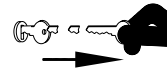

FIG. 4-12

3. Remove the rod/roll pin assembly far enough to clean out the seed meter cups as needed.

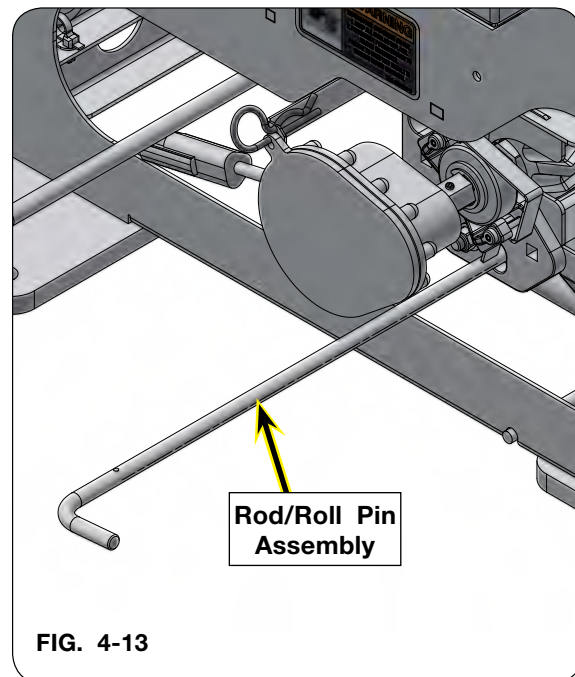

FIG. 4-13



### How To Clean Out Seed Meter Cups (continued)

4. Under the seed meter assembly, pull down on the seed cup at an angle and remove the seed cup and venturi nozzle.
5. Clean out the seed meter cups.
6. Replace the seed meter cups and venturi nozzles.

**NOTE:** Cover seeders with less than 12 hoses will have a plug in the venturis that do not have a hose connected.



FIG. 4-14



FIG. 4-15



FIG. 4-16

7. Install the rod/roll pin assembly to secure the seed meter cups.

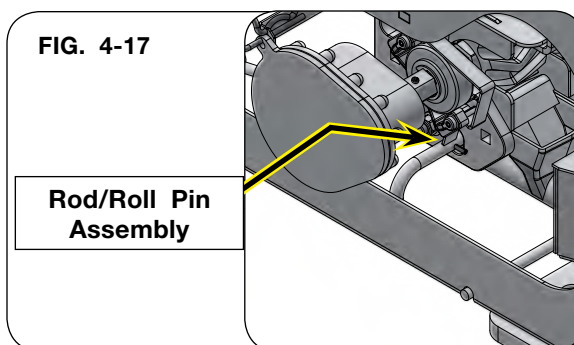

FIG. 4-17

Rod/Roll Pin  
Assembly

## How To Replace Seals In Fan Motor

### IMPORTANT

- When turning fan off, always place tractor SCV into **FLOAT**. Failure to do so will damage motor seals.

### SHAFT SIDE SEALS

1. Remove the spring retaining ring.
2. Remove and save the key from the shaft.
3. Remove and save the seal holder.
4. Remove the retaining ring.
5. Remove the seal and o-ring.
6. Apply grease and install the new seal and o-ring.

**NOTE:** O-ring has to pass over the spring retaining groove without being damaged.

7. Install retaining ring.
8. Replace the seal holder.
9. Reinstall the key onto the shaft.
10. Install spring retaining ring.

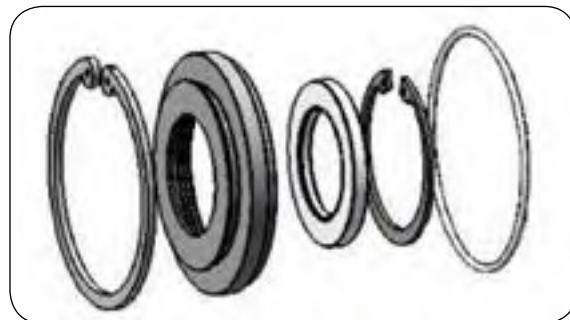

### REAR SEAL

1. Remove and save the four bolts.
2. Remove remove the lock washers.
3. Remove and save the cover.
4. Remove the o-ring.
5. Apply grease and install the new o-ring.
6. Replace the cover.
7. Use the new lock washers and reinstall the previously removed bolts. Torque to 22 ft.-lbs.
8. Refill the motor via the case drain before engaging the motor.

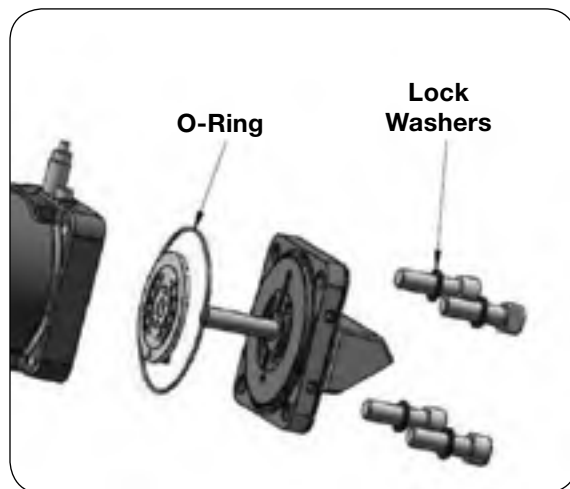

### Storage

Your implement is an important investment. Spend a little time to protect it from destructive rust and corrosion. You will be repaid in longer service life and better performance.

Do the following before placing the implement in storage:

1. Remove seed, dirt, and trash which could cause rusting.
2. Repaint any chipped or scraped areas.
3. Inspect for damage or worn parts, replace before next season.
4. Store implement inside, away from livestock.
5. Replace all worn, torn or faded decals and reflectors.

Electrical Layout - ISO-Bus Rate Controller

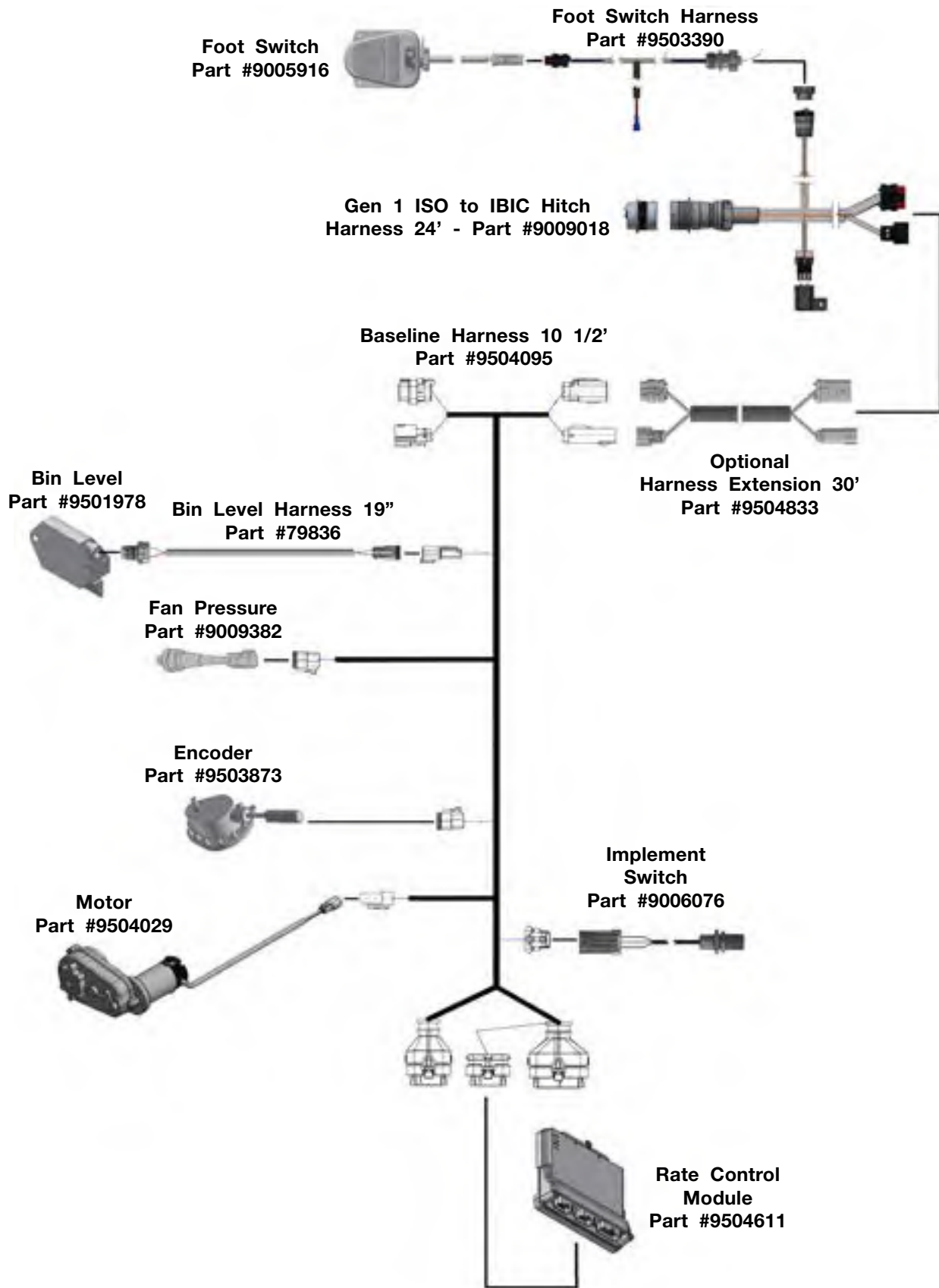

## Electrical Layout - Non ISO-Bus / Variable Rate Controller

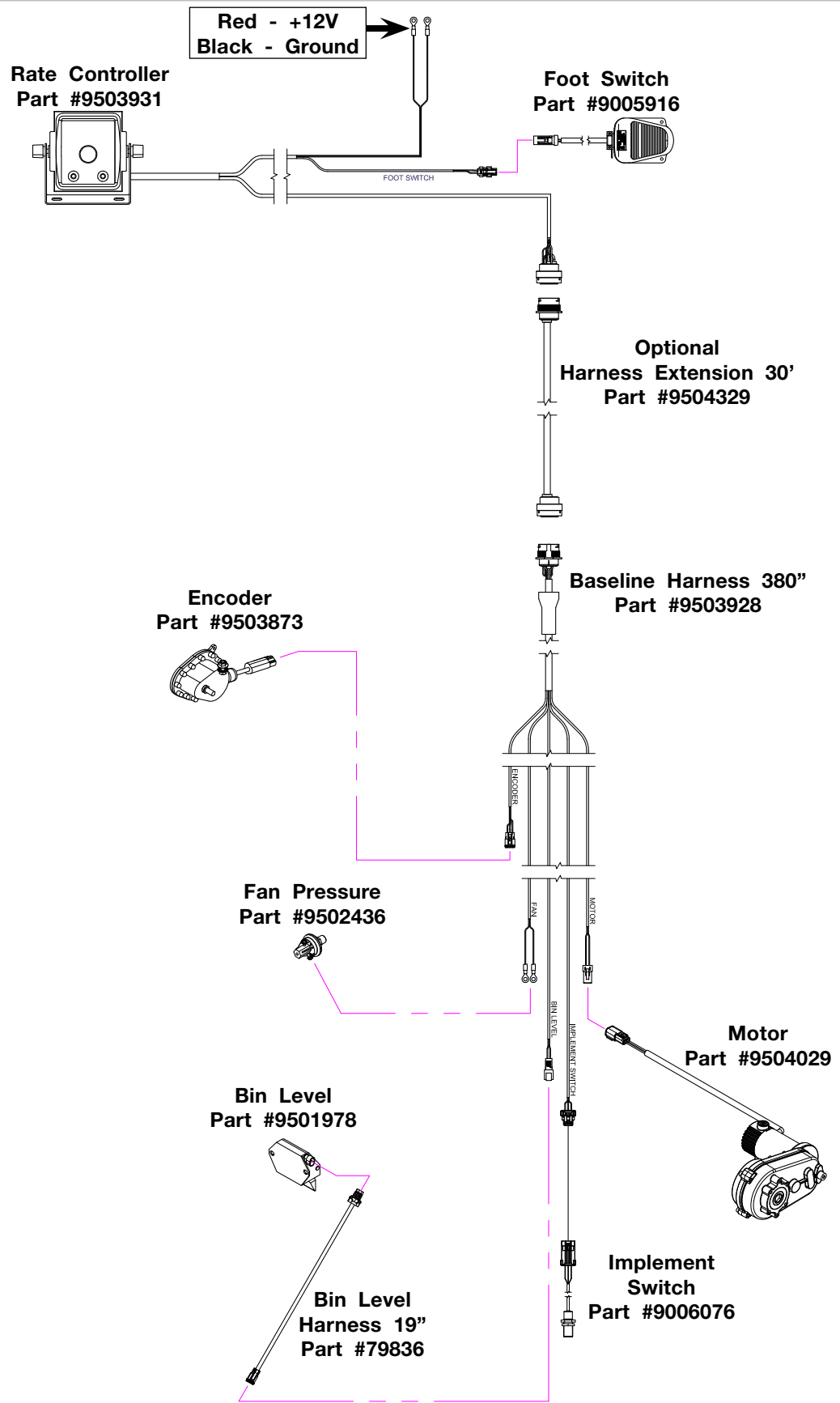



## Electrical Schematic - Gen 1 ISO to IBIC Hitch 24' #9009018

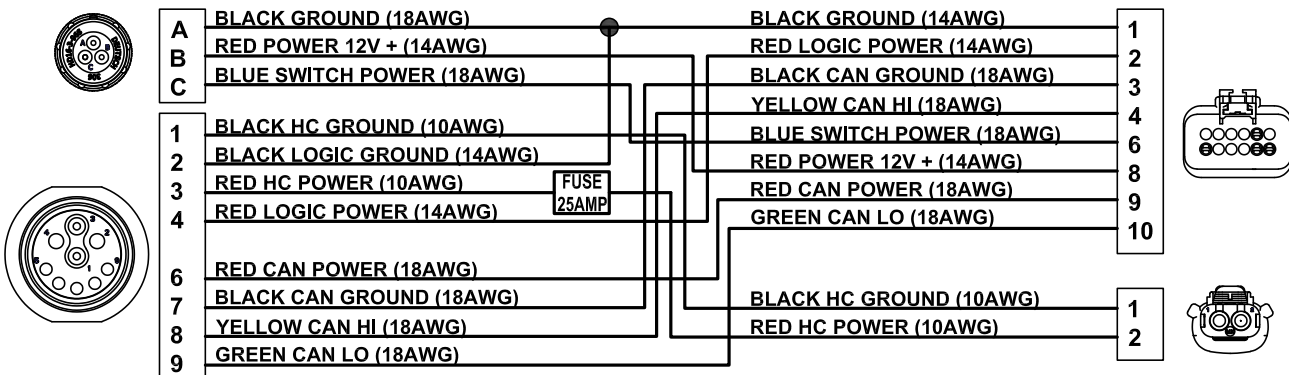

## Electrical Schematic - Foot Switch Harness #9503390

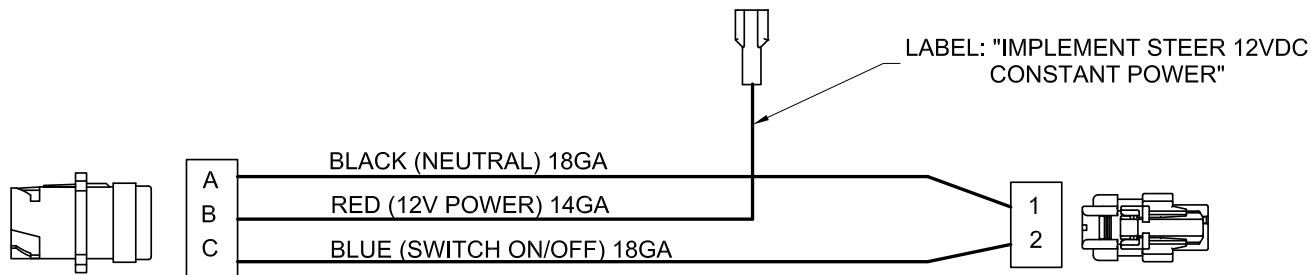

## Electrical Schematic - Encoder #9503873

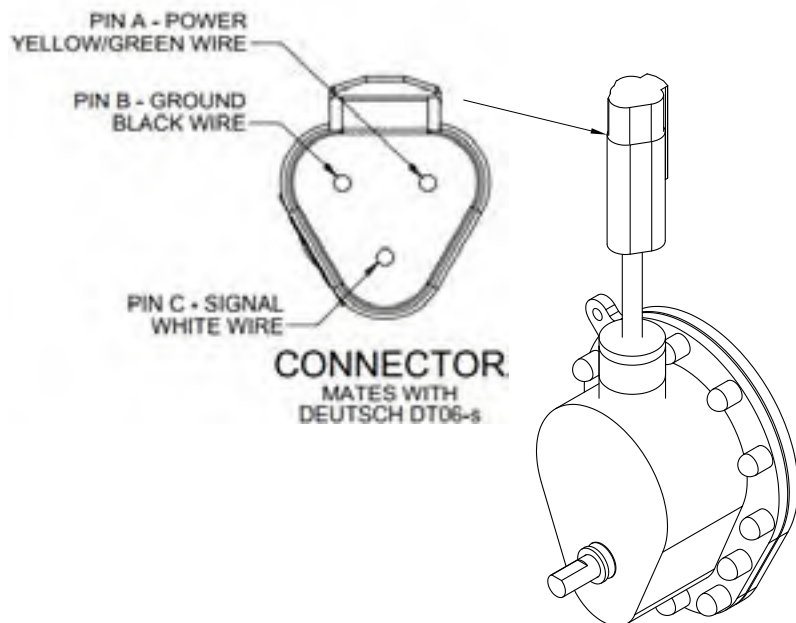





Electrical Schematic - Rate Controller #9503931

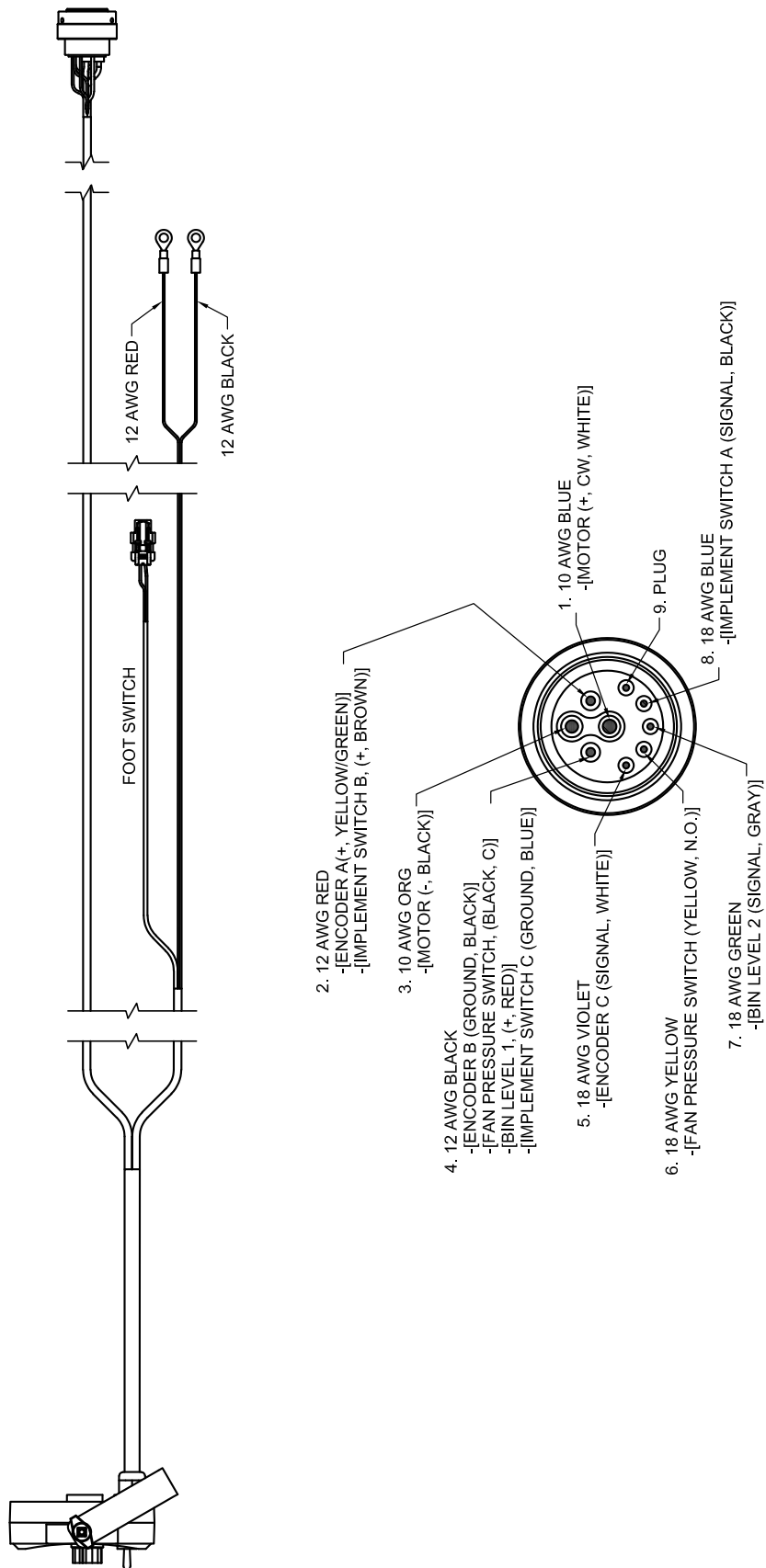

**Electrical Schematic - Motor #9504029**

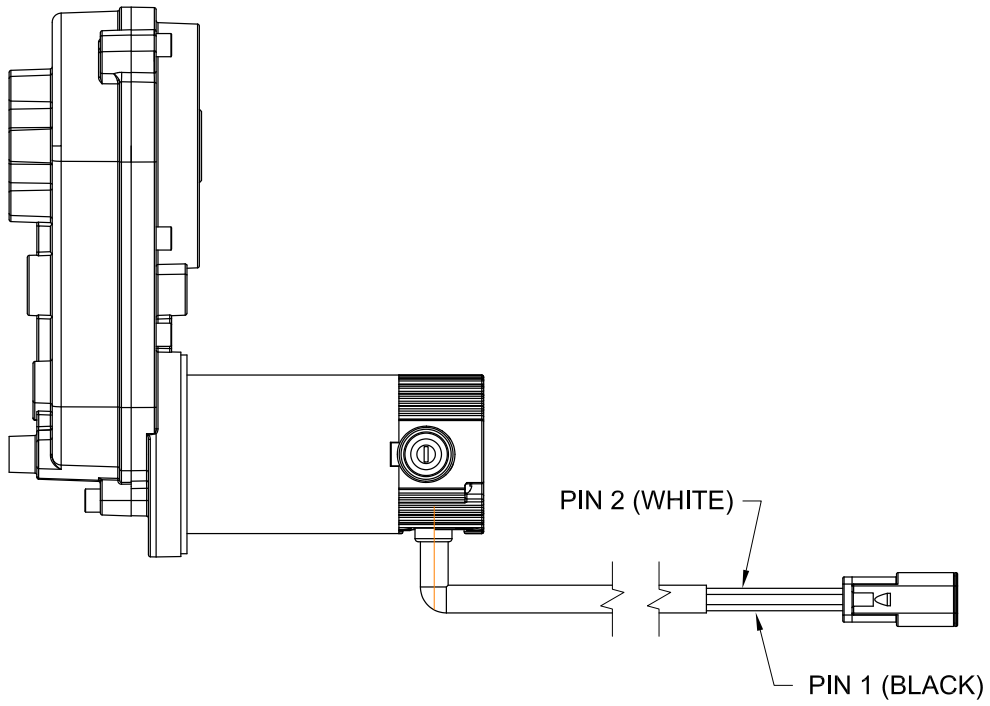

## Electrical Schematic - Baseline Harness 10 1/2' #9504095

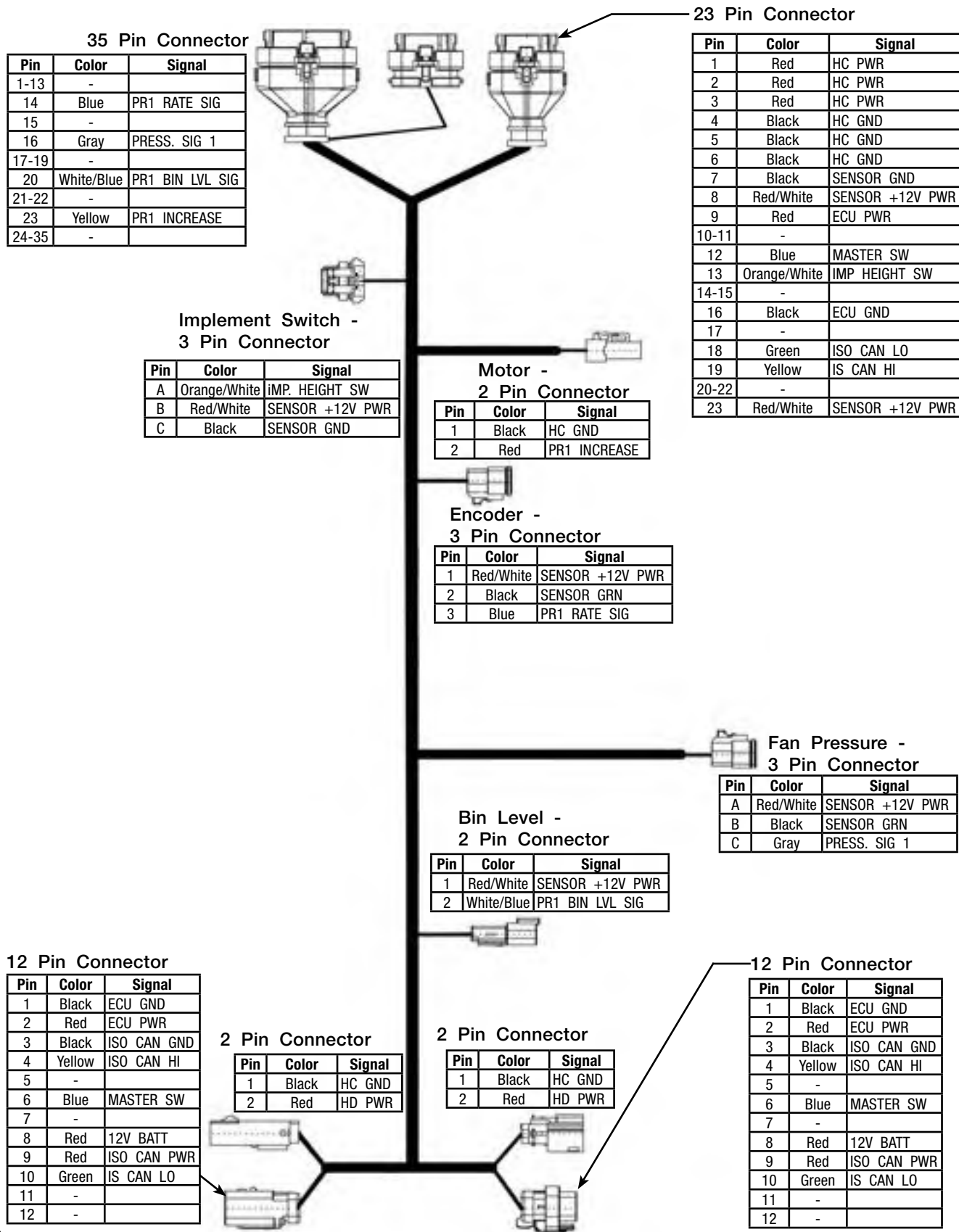

**Electrical Schematic - Opt. Harness Extension 30' #9504329**

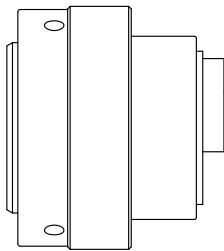

- |    |               |
|----|---------------|
| 1. | 10 AWG BLUE   |
| 2. | 12 AWG RED    |
| 3. | 10 AWG ORANGE |
| 4. | 12 AWG BLACK  |
| 5. | 18 AWG VIOLET |
| 6. | 18 AWG YELLOW |
| 7. | 18 AWG GREEN  |
| 8. | 18 AWG BLUE   |
| 9. | CAVITY PLUG   |

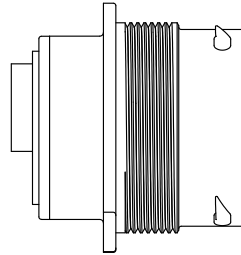

**Electrical Schematic - Opt. Harness Extension 30' #9504833**

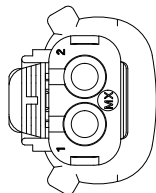
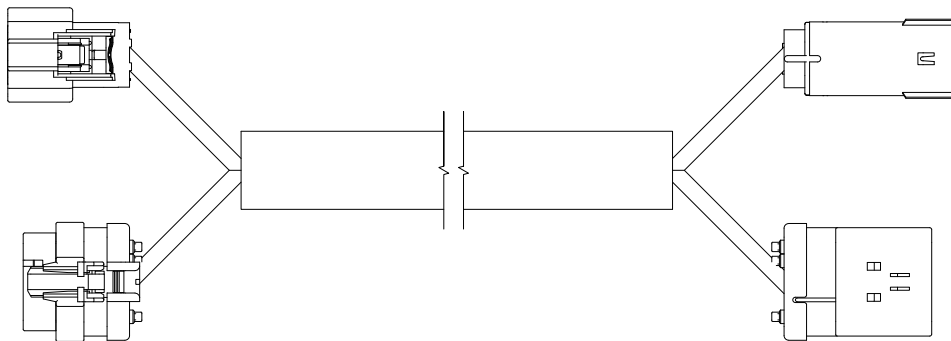

- |   |               |   |
|---|---------------|---|
| 1 | BLACK (10AWG) | 1 |
| 2 | RED (10AWG)   | 2 |

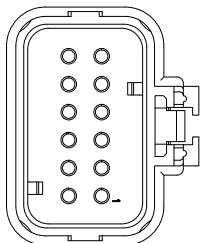
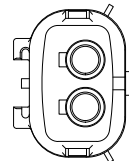

- |    |                |    |
|----|----------------|----|
| 1  | BLACK (16AWG)  | 1  |
| 2  | RED (16AWG)    | 2  |
| 3  | BLACK (18AWG)  | 3  |
| 4  | YELLOW (18AWG) | 4  |
| 6  | BLUE (18AWG)   | 6  |
| 8  | RED (18AWG)    | 8  |
| 9  | RED (18AWG)    | 9  |
| 10 | GREEN (18AWG)  | 10 |

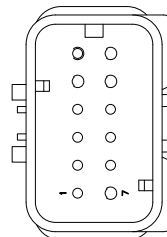

**CONNECTORS ARE SHOWN FROM THE WIRED END**

## Torque Chart - Capscrews - Grade 5

NOTE: Grade 5 capscrews can be identified by three radial dashes on head.

NOTE: For wheel torque requirements, refer to **Wheels and Tires**.

NOTE: Tighten U-bolts to have the same number of threads exposed on each end.

SIZE	FOOT POUNDS	NEWTON METERS	SIZE	FOOT POUNDS	NEWTON METERS
1/4-20	8-10	11-13	3/4-10	200-220	270-300
1/4-28	9-11	12-15	3/4-16	210-230	285-310
5/16-18	15-17	20-23	7/8-9	330-350	425-475
5/16-24	17-19	23-26	7/8-14	360-380	460-515
3/8-16	25-28	34-38	1-8	500-525	675-710
3/8-24	28-31	38-42	1-14	540-560	730-760
7/16-14	40-45	54-61	1 1/8-7	600-635	815-860
7/16-20	45-50	61-68	1 1/8-12	665-700	920-950
1/2-13	62-68	84-92	1 1/4-7	850-895	1150-1215
1/2-20	68-75	92-102	1 1/4-12	940-990	1275-1340
9/16-12	90-98	22-133	1 3/8-6	1125-1175	1525-1590
9/16-18	100-110	134-148	1 3/8-12	1280-1335	1735-1810
5/8-11	120-135	162-183	1 1/2-6	1500-1560	2035-2115
5/8-18	124-137	168-186	1 1/2-12	1685-1755	2285-2380

## Hydraulic Fittings - Torque and Installation

### SAE FLARE CONNECTION (JIC)

1. Tighten nut with finger until it bottoms the seat.
2. Using a wrench, rotate nut to tighten. Turn nut 1/3 turn to apply proper torque.

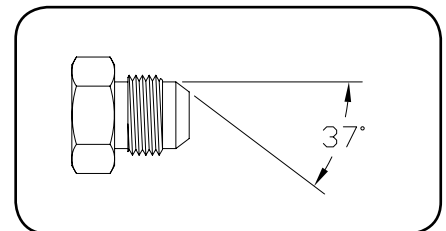

### SAE STRAIGHT THREAD O-RING SEAL

1. Insure jam nut and washer are backed up to the back side of smooth portion of elbow adapter.
2. Lubricate o-ring -- VERY IMPORTANT!
3. Thread into port until washer bottoms onto spot face.
4. Position elbows by backing up adapter.
5. Tighten jam nut.

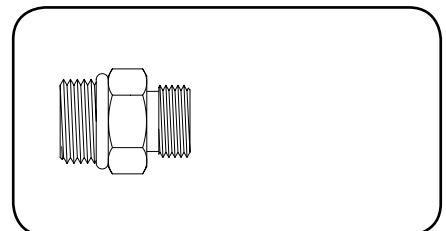

**Notes**

# **SECTION V**

# **Parts**

Tank Components.....	5-2
Seed Delivery Components.....	5-4
Seed Meter Assembly Components.....	5-6
Bracket, Nozzle & Mounting Components.....	5-8
Hydraulic Components.....	5-10
Electrical Components - ISO-Bus Rate Controller.....	5-12
Electrical Components - Non ISO-Bus / Variable Rate Controller.....	5-14
Tarp Components.....	5-16
Frame Brace Kit.....	5-18
Rolling Harrow Bolt Kit.....	5-19





## Cover Crop Seeder — Parts

### Tank Components

Please visit [www.unverferth.com/parts/](http://www.unverferth.com/parts/) for the most current parts listing.

ITEM	PART NO.	DESCRIPTION	QTY	NOTES
1	9390-055	Capscrew 3/8"-16UNC x 1" G5	2	
2	78560	Trim Edge 37"	A/R	
3	97617	Glass Window - Round	2	
4	22872	Weather Stripping 25 3/16" - Round	2	
5	102608	Glass Window - Rectangular	1	
6	102693	Weather Stripping 30" - Rectangular	1	
7	93551	Decal, WARNING (Hydraulic Pressure...)	1	
8	9504711	Decal, Stripe with UM Logo & CC Seeder	2	
9	9504841	Decal, Stripe with UM Logo	1	
10	9504843	Decal, Stripe with CC Seeder	1	
11	98350	Decal, WARNING (No Riders...)	1	
12	TA1-906109-0	Decal, WARNING (Moving Parts...)	2	
13	9390-101	Capscrew 1/2"-13UNC x 1 1/2" G5	4	
14	9405-088	Flat Washer 1/2"	8	
15	9800	Lock Nut 1/2"-13UNC	14	
16	9928	Lock Nut/Top 3/8"-16UNC	14	
17	77622G	Front Cover Crop Stand Weldment =Green=	1	ROLLING HARROW with Serial Number A58720200 & up with center support
	77622R	Front Cover Crop Stand Weldment =Red=		
18	77807G	Front Cover Crop Stand Weldment =Green=	1	ROLLING HARROW with Serial Number A64740100 & up no center support
	77807R	Front Cover Crop Stand Weldment =Red=		
19	77811G	Front Cover Crop Stand Weldment =Green=	1	
	77811R	Front Cover Crop Stand Weldment =Red=		
20	78281B	Step Weldment	1	
21	96568	U-Bolt 1/2"-13UNC x 5 1/8"	2	
22	9502320	U-Bolt 1/2"-13UNC x 4 1/16"	5	
23	91605	Decal, FEMA	1	
24	91252	Decal, Warranty Consideration	1	

# Cover Crop Seeder — Parts

## Seed Delivery Components

Please visit [www.unverferth.com/parts/](http://www.unverferth.com/parts/) for the most current parts listing.

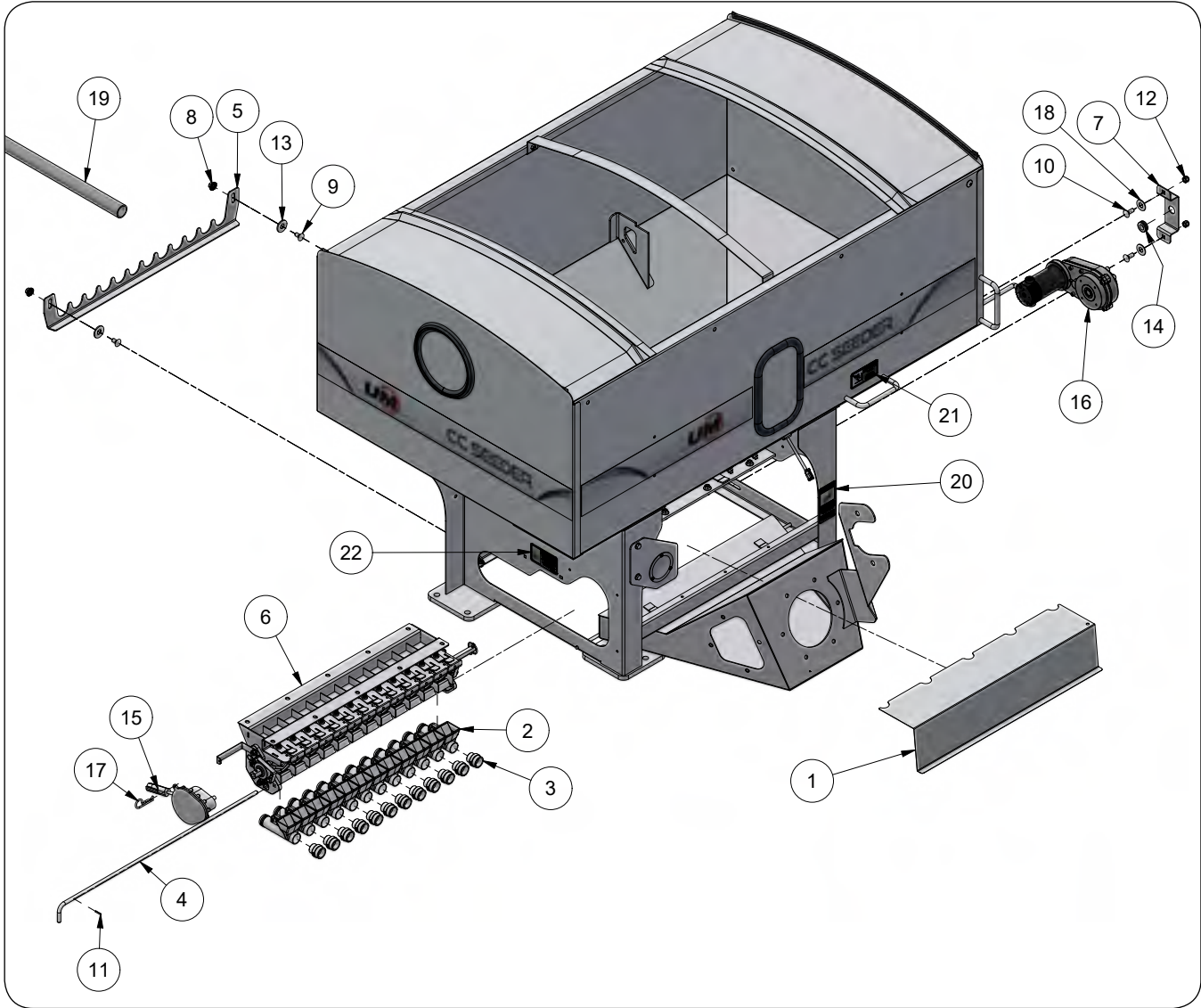

## Cover Crop Seeder — Parts

### Seed Delivery Components

Please visit [www.unverferth.com/parts/](http://www.unverferth.com/parts/) for the most current parts listing.

ITEM	PART NO.	DESCRIPTION	QTY	NOTES
1	700071B	Cover =Black=	1	
2	77557	Seed Cup, 2" Wheel, 1 1/4" Dia. Hose	12	
3	77561	Venturi .45" Nozzle	12	
4	77572	Rod 3/8" Dia.	1	
5	77614B	Hose Pocket 1 1/4"	1	
6	79851B	Seed Meter Assembly 12 Cups	1	
7	79944B	Anti-Rotation Bracket	1	
8	91263	Nut/Large Flange 3/8"-16UNC	6	
9	9388-050	Carriage Bolt 3/8"-16UNC x 3/4" G5	2	
10	9388-051	Carriage Bolt 3/8"-16UNC x 1" G5	4	
11	9392-056	Roll Pin 1/8" Dia. x 3/4"	1	
12	9398-012	Elastic Lock Nut 3/8"-16UNC	5	
13	9405-088	Flat Washer, 1/2" USS	6	
14	9500823	Grommet, 5/8" ID	1	
15	9503873	Rotary Encoder	1	
16	9504029	Hollow Hex Shaft Offset Gearmotor	1	
17	9806	Hairpin Cotter, 0.148" Dia. x 2 9/16"	1	
18	JBP3457	Flat Washer, 1/2" (Stainless Steel)	2	
19	9502270	PVC Air Hose 1 1/4"	A/R	
20	93551	Decal, WARNING (High-Pressure Fluids...)	1	
21	98350	Decal, WARNING (No Rider...)	1	
22	TA1-906109-0	Decal, WARNING (Moving Parts...)	2	

## Seed Meter Assembly Components

Please visit [www.unverferth.com/parts/](http://www.unverferth.com/parts/) for the most current parts listing.

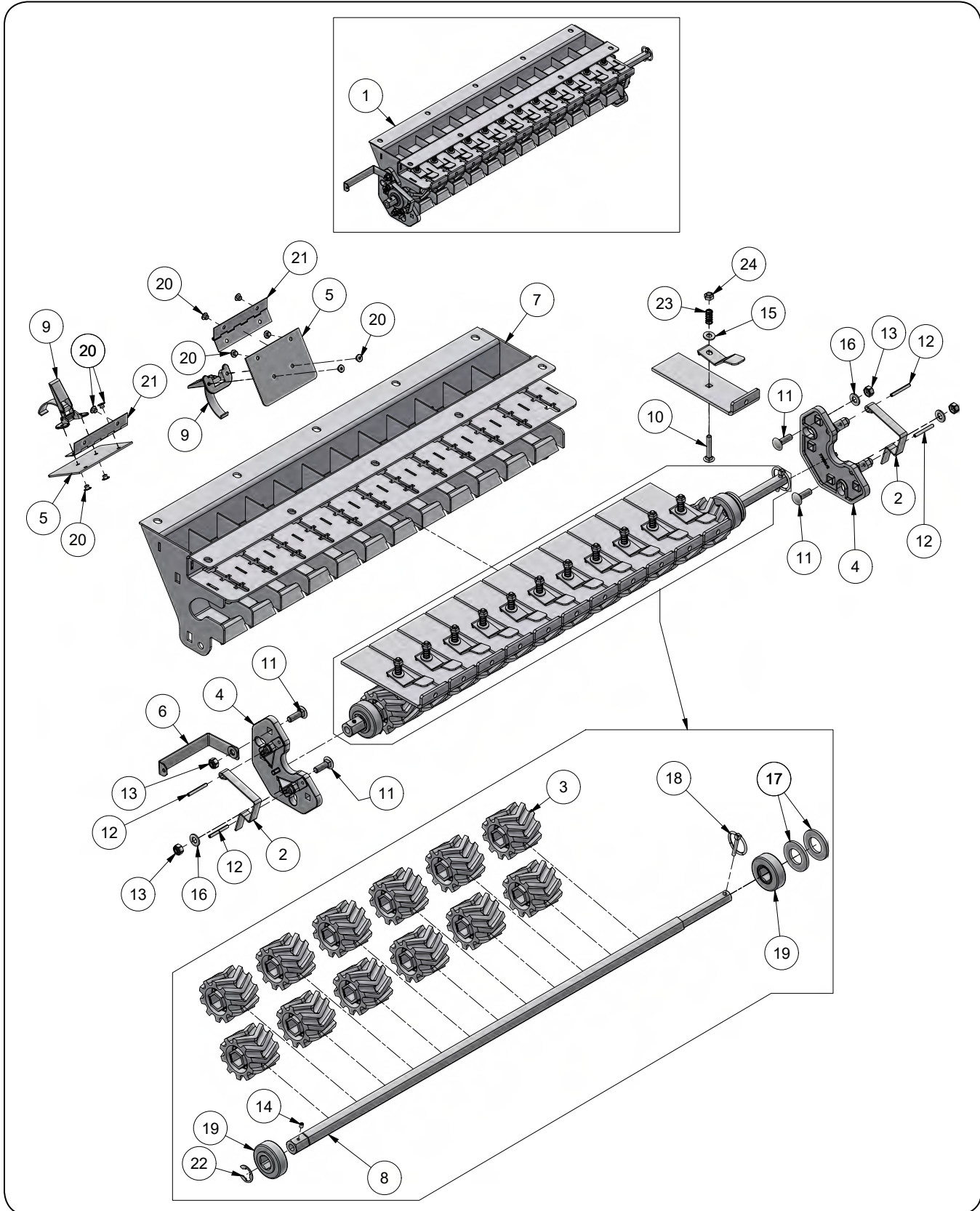

## Cover Crop Seeder — Parts

### Seed Meter Assembly Components

Please visit [www.unverferth.com/parts/](http://www.unverferth.com/parts/) for the most current parts listing.

ITEM	PART NO.	DESCRIPTION	QTY	NOTES
1	79851B	Seed Meter Assembly 12 Cups	1	Includes Items 2-24
2	41490	Flat Bar Spring	2	
3	77476	Meter Roller 2 1/2" Dia. x 2" Chevron Pattern	12	
4	77551	Bearing Holder	2	
5	78423B	Door =Black=	2	
6	79815B	Anti-Rotation Bracket		
7	79858B	Metering Device Weldment - 12 Outlet =Black=	1	
8	79908	Meter Roller Shaft	1	
9	9220	Draw Latch	2	
10	9388-005	Carriage Bolt, 1/4"-20UNC x 1 1/2" G5	12	
11	9388-025	Carriage Bolt, 5/16"-18UNC x 1" G5	4	
12	9392-081	Roll Pin, 5/32" Dia. x 1 3/8"	4	
13	9398-010	Elastic Lock Nut, 5/16"-18UNC	4	
14	9399-047	Set Screw, #10-24 x 1/4"	1	
15	9405-062	Flat Washer, 1/4" SAE	12	
16	9405-068	Flat Washer, 5/16" SAE	4	
17	9405-110	Flat Washer, 7/8" SAE	4	
18	9500226	Klik Pin, 3/16" Dia. x 1"	1	
19	9502259	Hex Bearing, 3/4"	2	
20	9502727	Rivet, 3/16" Dia.	12	
21	9502945	Piano Hinge, 1 1/2" x 4"	2	
22	9503874	Retaining E-Ring External, 3/4" Shaft Dia.	1	
23	9504201	Compression Spring, .354" Dia. x .748"	12	
24	9936	Locknut/Top, 1/4"-20UNC	12	

## Bracket, Nozzle & Mounting Components

Please visit [www.unverferth.com/parts/](http://www.unverferth.com/parts/) for the most current parts listing.

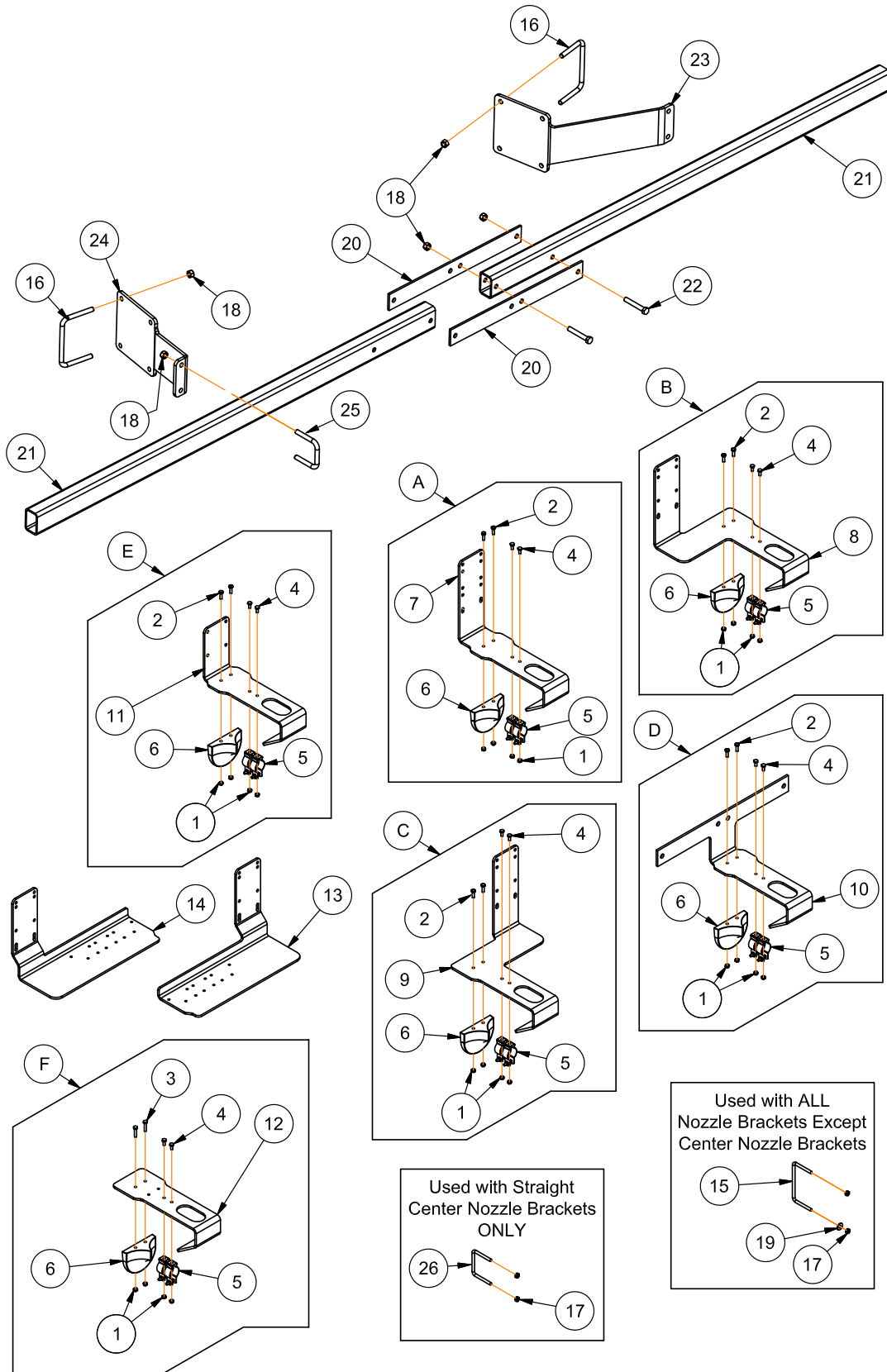

# Cover Crop Seeder — Parts

## Bracket, Nozzle & Mounting Components

Please visit [www.unverferth.com/parts/](http://www.unverferth.com/parts/) for the most current parts listing.

ITEM	PART NUMBER	DESCRIPTION	QTY PER UNIT SIZE															
			18'	20'	21'	22'	23'	24'	25'	26'	27'	28'	29'	30'	31'	33'	35'	37'
A	77625B	Straight Nozzle Bracket Asy	2	2	2	-	2	4	2	4	4	4	-	2	4	6	4	2
B	77712B	Right-Hand Nozzle Bracket Asy	-	-	-	2	1	-	1	-	-	-	3	1	1	-	2	2
C	77713B	Left-Hand Nozzle Bracket Asy	-	-	-	2	1	-	1	-	-	-	3	1	1	-	2	2
D	78421B	Straight Spliced Center Nozzle Bracket Assembly	-	-	-	1	1	1	-	-	-	-	1	1	1	-	1	-
E	77850B	Straight Center Nozzle Bracket Assembly	4	4	4	2	2	2	4	4	4	4	2	2	2	4	2	4
F	78147B	Bolt-Together Nozzle Bracket Assembly	-	-	-	-	-	-	-	-	-	-	-	2	-	-	-	2
1	9936	Lock Nut/Top 1/4-20UNC	24	24	24	28	28	28	32	32	32	32	36	36	36	40	44	48
2	9390-004	Capscrew 1/4"-20UNC x 7/8"	12	12	12	14	14	14	16	16	16	16	18	14	18	20	22	20
3	9390-006	Capscrew 1/4"-20UNC x 1 1/4"	-	-	-	-	-	-	-	-	-	-	-	4	-	-	-	4
4	9390-002	Capscrew 1/4"-20UNC x 5/8"	12	12	12	14	14	14	16	16	16	16	18	18	18	20	22	24
5	9502927	Conduit Clamp 1 1/4 EMT	12	12	12	14	14	14	16	16	16	16	18	18	18	20	22	24
6	78593B	Nozzle-Fan Cover Crop	6	6	6	7	7	7	8	8	8	8	9	9	9	10	11	12
7	77623B	Straight Nozzle Bracket	2	2	2	-	2	4	2	4	4	4	-	2	4	6	4	2
8	77704B	Right-Hand Nozzle Bracket	-	-	-	2	1	-	1	-	-	-	3	1	1	-	2	2
9	77705B	Left-Hand Nozzle Bracket	-	-	-	2	1	-	1	-	-	-	3	1	1	-	2	2
10	78420B	Straight Spliced Center Nozzle Bracket	-	-	-	1	1	1	-	-	-	-	1	1	1	-	1	-
11	77849B	Straight Center Nozzle Bracket	4	4	4	2	2	2	4	4	4	4	2	2	2	4	2	4
12	78143B	Bolt-Together Nozzle Bracket	-	-	-	-	-	-	-	-	-	-	-	2	-	-	-	2
13	78146B	Left-Hand Nozzle Bracket (Long)	-	-	-	-	-	-	-	-	-	-	-	2	-	-	-	1
14	78145B	Right-Hand Nozzle Bracket (Long)	-	-	-	-	-	-	-	-	-	-	-	2	-	-	-	1
15	9502370	U-Bolt 5/16"-18UNC x 2 3/4"	4	4	4	8	8	8	8	8	8	8	12	12	12	12	16	16
16	9502320	U-Bolt 1/2"-13UNC x 4 1/16"	4	4	4	4	4	4	4	4	4	4	4	4	4	4	4	4
17	9807	Lock Nut/Top 5/16"-18UNC	24	24	24	24	24	24	32	32	32	32	32	32	32	40	40	48
18	9800	Lock Nut/Top 1/2"-13UNC	16	16	16	16	16	16	16	16	16	16	16	16	16	16	16	16
19	9405-070	Flat Washer 5/16" USS	4	4	4	8	8	8	8	8	8	8	12	12	12	12	16	16
20	78419B	Plate 2 1/4" x 21 5/8"	2	2	2	1	1	1	2	2	2	2	1	1	1	2	1	2
21	78418B	Tube 3" x 2" x 3/16" x 65 1/4"	2	2	2	2	2	2	2	2	2	2	2	2	2	2	2	2
22	9390-108	Capscrew 1/2"-13UNC x 3 1/4"	4	4	4	4	4	4	4	4	4	4	4	4	4	4	4	4
23	77647B	Left-Hand Tube Mount Plate	1	1	1	1	1	1	1	1	1	1	1	1	1	1	1	1
24	77646B	Right-Hand Tube Mount Plate	1	1	1	1	1	1	1	1	1	1	1	1	1	1	1	1
25	96566	U-Bolt 1/2"-13UNC x 3 1/4"	2	2	2	2	2	2	2	2	2	2	2	2	2	2	2	2
26	9005281	U-Bolt 5/16"-18UNC x 2 3/4"	8	8	8	4	4	4	8	8	8	8	4	4	4	8	4	8



# Cover Crop Seeder — Parts

## Hydraulic Components

Please visit [www.unverferth.com/parts/](http://www.unverferth.com/parts/) for the most current parts listing.

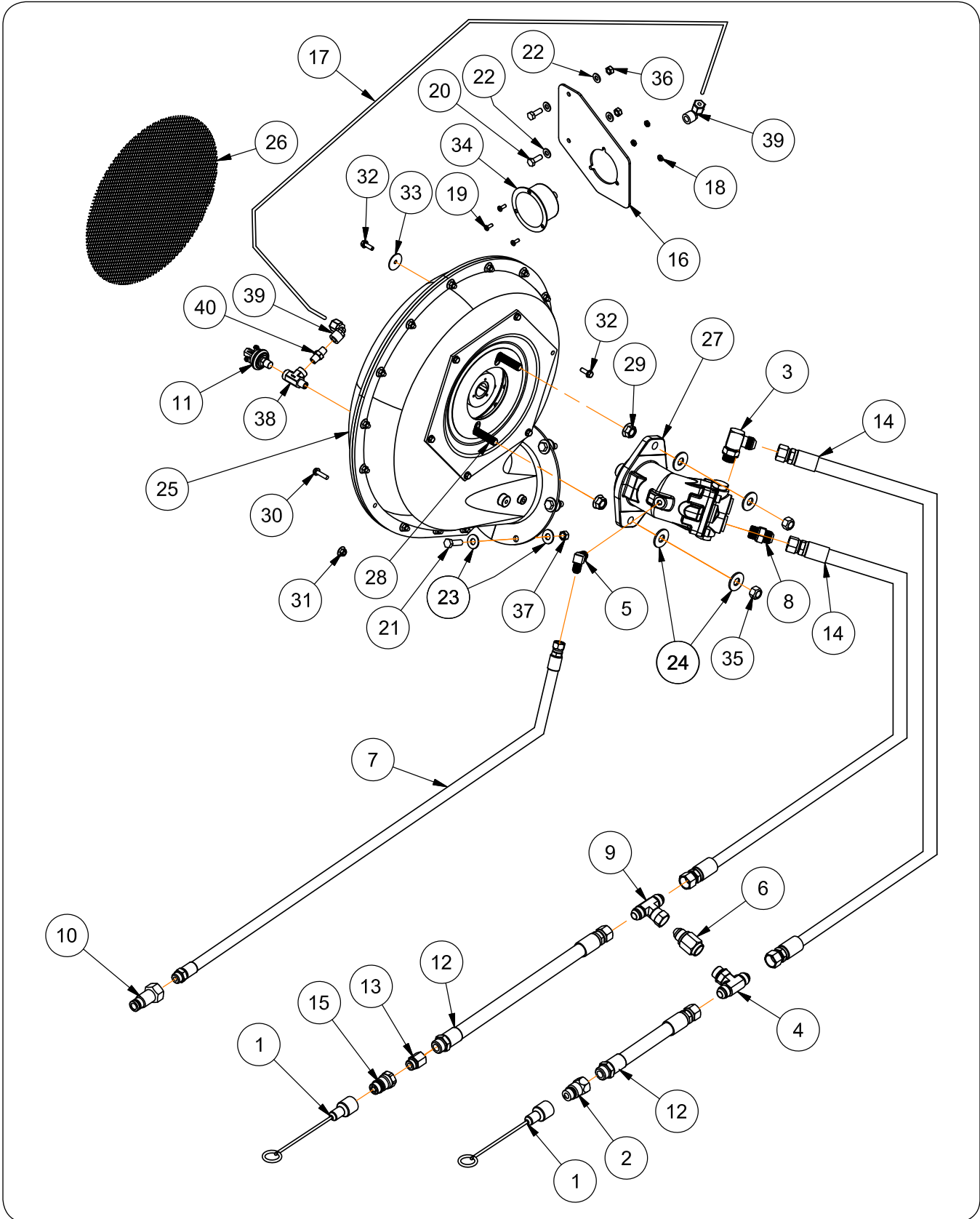



# Cover Crop Seeder — Parts

## Hydraulic Components

Please visit [www.unverferth.com/parts/](http://www.unverferth.com/parts/) for the most current parts listing.

ITEM	PART NO.	DESCRIPTION	QTY	NOTES
1	91511	Dust Cap	2	
2	95477	Pioneer Male Tip 7/8"-14 Female	2	
3	95540	90° Elbow, 7/8-14 JIC Male x 7/8-14 O-Ring Male	1	
4	95541	Tee, 7/8-14 JIC Male x 7/8-14 JIC male x 7/8-14 O-Ring Male	2	
5	97445	90° Elbow, 9/16-18 JIC Male x 9/16-18 O-Ring Male	1	
6	902729	Check Valve, 7/8-14UNF-2B Female/Male Ends	2	
7	9002286	Hose, 3/8" x 288" (9/16-18 JIC Female x 3/4-16 O-Ring Male)	1	
8	9002443	Adapter 7/8"-14 JIC Male x 7/8"-14 O-Ring Male	1	
9	9002465	Tee, 7/8-14 JIC Male x 7/8-14 JIC Male x 7/8-14 JIC Female	2	
10	9006048	Coupler Tip, 3/4-16 Male, Flat Face 3/8" Body	2	
11	9502436	Pressure Switch	1	
12	9502984	Hose, 5/8" x 288" (7/8-14 JIC Female x 7/8-14 O-Ring Male)	2	
13	9503039	Adapter, 3/4-16 O-Ring Male x 7/8-14 O-Ring Female	2	
14	9503989	Hose, 3/8" x 30" (7/8-14 JIC Female x 7/8-14 JIC Female)	2	
15	PF1202-8434	Connect, 3/4-16 O-Ring Male Quick Connect - Return	2	
16	79829B	Plate, 7 x 7 1/2"	1	
17	79989	Gauge Tubing, 1/4" Dia. x 24"	1	
18	9006882	Locknut/Top, #10-24UNC	3	
19	903172-133	Pan Head, #10-24UNC x 1/2" (Phillips, Machine Screw)	3	
20	9390-029	Capscrew, 5/16-18UNC x 7/8" G5	2	
21	9390-056	Capscrew, 3/8"-16UNC x 1 1/4" G5	6	
22	9405-068	Flat Washer, 5/16" SAE	4	
23	9405-076	Flat Washer 3/8" USS	12	
24	9405-088	Flat Washer 1/2" USS	6	
25	9502296	Aluminum Fan 6" Flanged Outlet Forward Curved Impeller	1	
26	9503544	Inlet Screen	1	
27	9502587	Hydraulic Motor 12CC Bent Axis Piston Max 6000RPM @ 5800PSI	1	
	9502586	Seal Kit	-	
28	9503549	Hex Head Flange Bolt, 1/2"-13UNC x 2 1/4"	2	
29	91267	Flange Nut, 1/2"-13UNC	2	
30	901101	Flange Screw, 1/4"-20UNC x 1" G5	15	
31	97189	Hex Nut/Large Flange, 1/4"-20UNC	15	
32	97420	Flange Screw, 1/4"-20UNC x 3/4" G5	12	
33	105005	Fender Washer, 1 1/4" OD x 1/4" ID	6	
34	9503608	Pressure Gauge 0-60" Water, Front Mount	1	
35	9800	Locknut/Top, 1/2"-13UNC	2	
36	9807	Locknut/Top, 5/16-18UNC	8	
37	9928	Locknut/Top, 3/8"-16UNC	12	
38	TA0-934667-0	Street Tee, 4MPT-4FPT-4FPT	1	
39	TA720812	90° Elbow, 1/4FPT x 1/4 Tube	2	
40	TA809325	1/4" Hex Pipe Nipple (Nylon)	1	

# Cover Crop Seeder — Parts

## Electrical Components - ISO-Bus Rate Controller

Please visit [www.unverferth.com/parts/](http://www.unverferth.com/parts/) for the most current parts listing.

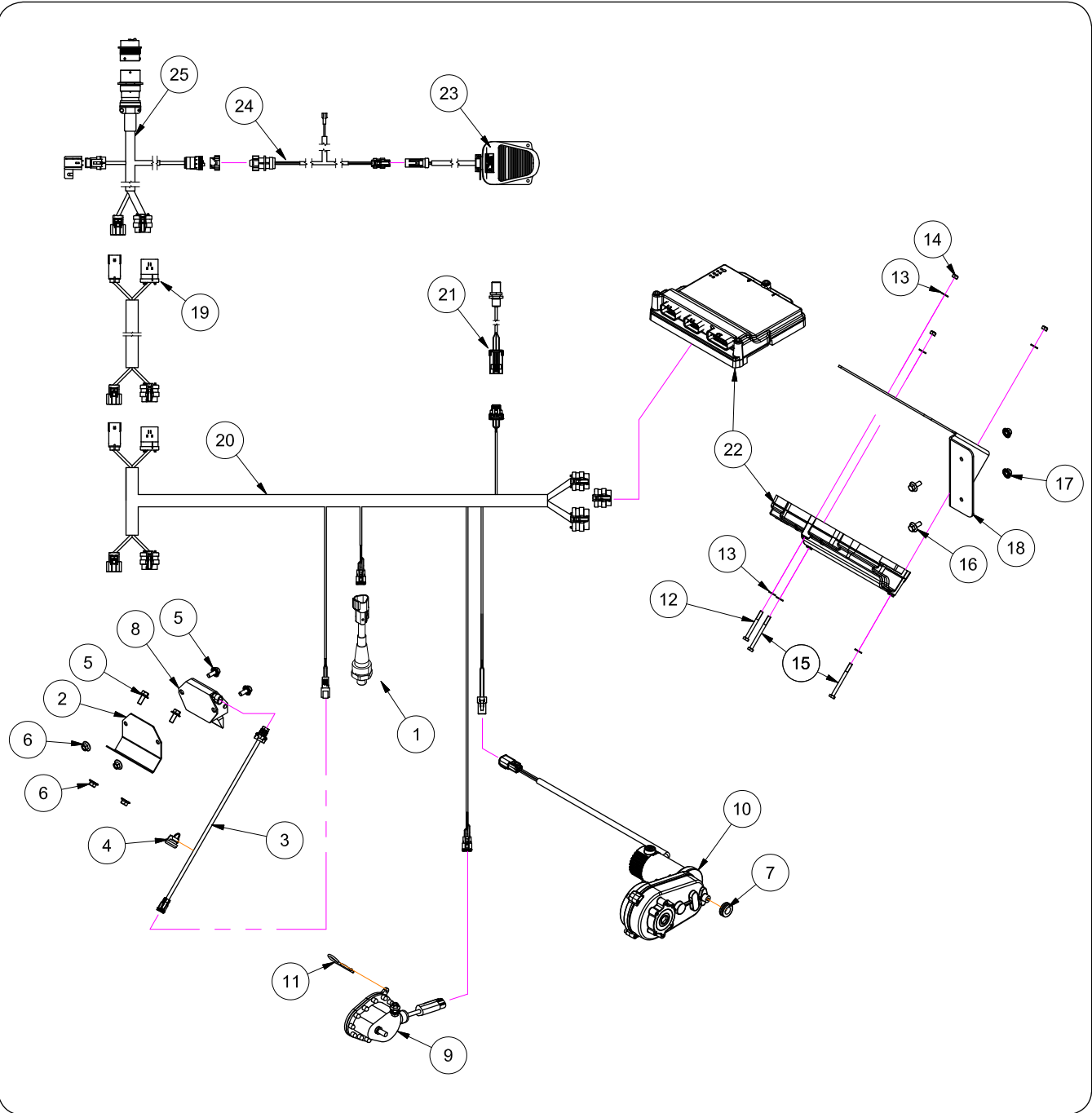

## Cover Crop Seeder — Parts

### Electrical Components - ISO-Bus Rate Controller

Please visit [www.unverferth.com/parts/](http://www.unverferth.com/parts/) for the most current parts listing.

ITEM	PART NO.	DESCRIPTION	QTY	NOTES
1	9009382	Fan/Pressure Switch	1	
2	78931B	Bin Level Switch Mount Plate =Black=	1	
3	79836	Bin Level Wire Harness, 19"	1	
4	901229	Cord Grip Fitting/Snap-In	1	
5	91256	Flange Screw, 5/16"-18UNC x 3/4" G5	4	
6	91257	Hex Nut/Large Flange, 5/16"-18UNC	e4	
7	9500823	Grommet, 5/8" ID	1	
8	9501978	Magnetic Reed Switch	1	
9	9503873	Rotary Encoder	1	
10	9504029	Hollow Shaft Offset Gearmotor With Harness	1	
11	9806	Hairpin Cotter, 2 9/16"	1	
12	9390-011	Capscrew, 1/4"-20UNC x 2 1/2" G5	1	
13	9405-062	Flat Washer, 1/4" SAE	6	
14	9936	Locknut/Top, 1/4"-20UNC	3	
15	9390-013	Capscrew, 1/4"-20UNC x 3" G5	2	
16	91256	Flange Screw, 5/16"-18UNC x 3/4" G5	2	
17	91257	Hex Nut/Large Flange, 5/16"-18UNC	2	
18	79813B	RCM Mounting Bracket =Black=	1	
19	9504833	Wire Harness Extension, 30" (Optional)	1	
20	9504095	Baseline Wire Harness, 10 1/2'	1	
21	9006076	Implement/Proximity Sensor With Harness	1	
22	9504611	Rate Control Module	1	
23	9005916	Foot Switch With Harness	1	
24	9503390	Foot Switch Harness	1	
25	9009018	GEN 1 ISO to IBIC Hitch Harness, 24'	1	

# Cover Crop Seeder — Parts

## Electrical Components - Non ISO-Bus / Variable Rate Controller

Please visit [www.unverferth.com/parts/](http://www.unverferth.com/parts/) for the most current parts listing.

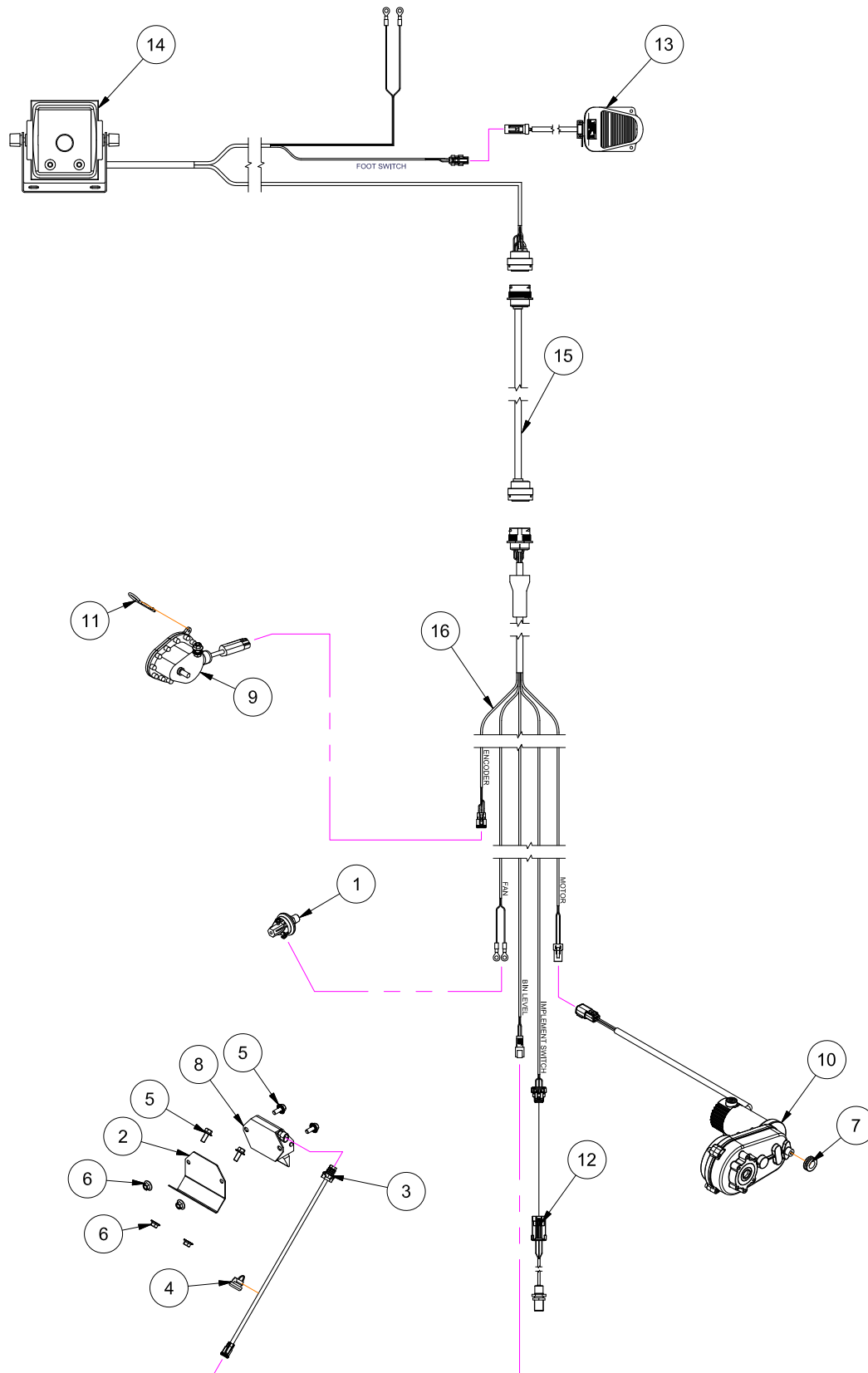

## Cover Crop Seeder — Parts

### Electrical Components - Non ISO-Bus / Variable Rate Controller

Please visit [www.unverferth.com/parts/](http://www.unverferth.com/parts/) for the most current parts listing.

ITEM	PART NO.	DESCRIPTION	QTY	NOTES
1	9502436	Fan/Pressure Switch	1	
2	78931B	Bin Level Switch Mount Plate =Black=	1	
3	79836	Bin Level Wire Harness, 19"	1	
4	901229	Cord Grip Fitting/Snap-In	1	
5	91256	Flange Screw, 5/16"-18UNC x 3/4" G5	4	
6	91257	Hex Nut/Large Flange, 5/16"-18UNC	e4	
7	9500823	Grommet, 5/8" ID	1	
8	9501978	Magnetic Reed Switch	1	
9	9503873	Rotary Encoder	1	
10	9504029	Hollow Shaft Offset Gearmotor With Harness	1	
11	9806	Hairpin Cotter, 2 9/16"	1	
12	9006076	Implement/Proximity Sensor With Harness	1	
13	9005916	Foot Switch With Harness	1	
14	9503931	Rate Controller, 12V DC With 106" Harness	1	
15	9504329	Wire Harness Extension, 30" (Optional)	1	
16	9503928	Baseline Wire Harness, 380"	1	

# Cover Crop Seeder — Parts

## Tarp Components

Please visit [www.unverferth.com/parts/](http://www.unverferth.com/parts/) for the most current parts listing.

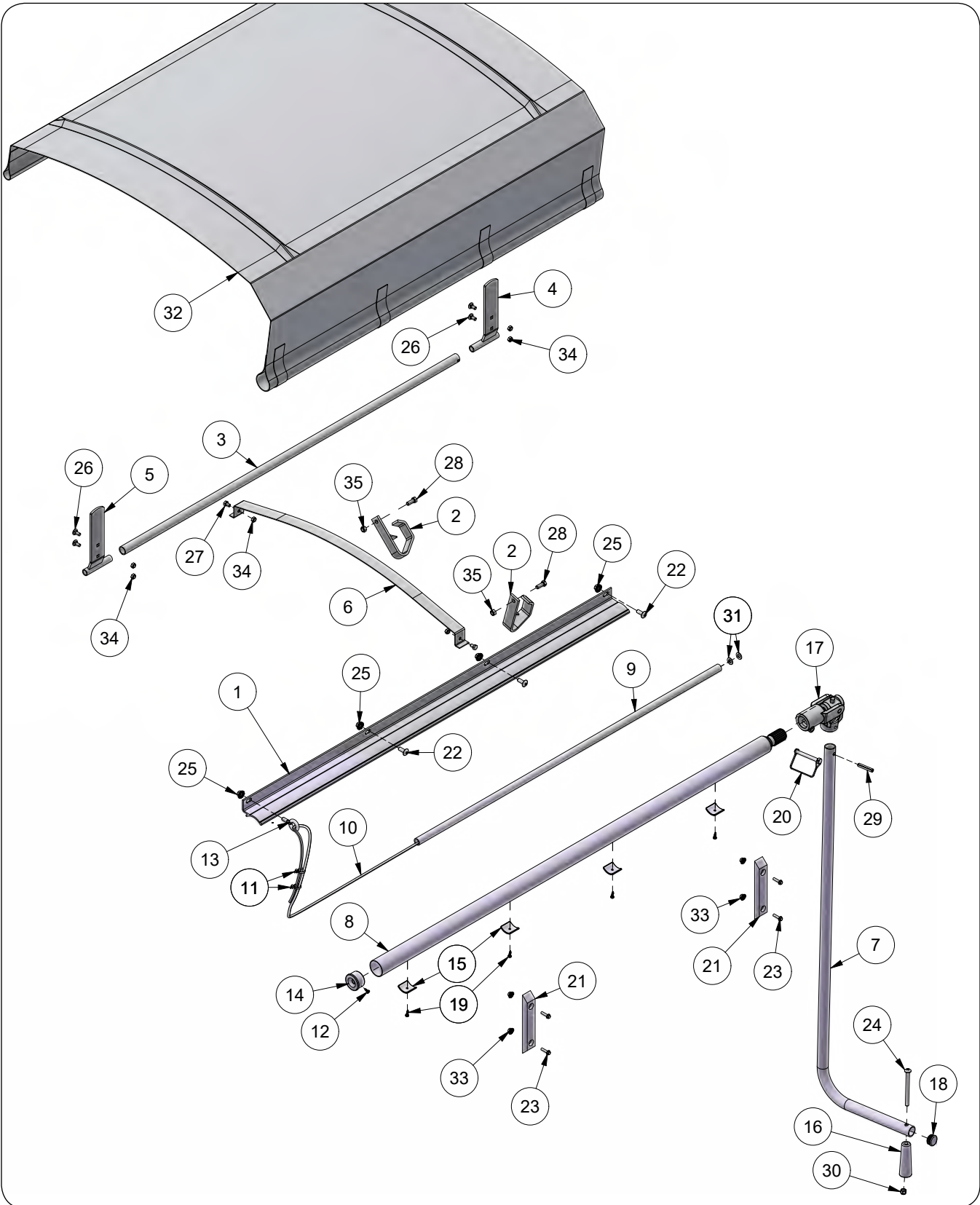

## Cover Crop Seeder — Parts

### Tarp Components

Please visit [www.unverferth.com/parts/](http://www.unverferth.com/parts/) for the most current parts listing.

ITEM	PART NO.	DESCRIPTION	QTY	NOTES
1	2012313	Latch Plate 58 1/2"	1	
2	221770B	Handle Retainer Weldment =Black=	2	
3	77640B	Tube 1" OD x 53 1/8" =Black=	1	
4	77643B	Tarp Mount LH Weldment =Black=	1	
5	77644B	Tarp Mount RH Weldment =Black=	1	
6	77720B	Tarp Bow =Black=	1	
7	78298	Tube Handle	1	
8	78305	Roll Tube Weldment	1	
9	78306	PVC Pipe 1/2" SCH40 x 48"	1	
10	78311	Bungee 1/4" x 68"	1	
11	9000106	Cable Tie 7 1/2"	10	
12	9001396	Screw/Self-Drilling #10-16 x 1/2"	1	
13	9004548	Eye Bolt 3/8"-16UNC x 1 3/4"	1	
14	9004947	Plug 1 7/8" Dia.	1	
15	9004949	U-Clamp 1 9/16" x 1 1/2"	4	
16	9004969	Handle (Black)	1	
17	9004977	U-Joint w/ 1 3/8-21 Spline	1	
18	9005089	Plug 1 1/4" Dia.	1	
19	9005197	Screw/Self-Drilling #10-16 x 3/4"	4	
20	9005305	Lynch Pin 3/8" Dia. x 3"	1	
21	9005307	Deflector (Black)	2	
22	9005312	Truss head 3/8"-16UNC x 1" G5	3	
23	901101	Flange Screw 1/4-20UNC x 1" G5	4	
24	903172-450	Pan Head 3/8"-16UNC x 4 1/2" Phillips	1	
25	91263	Nut/Large Flange 3/8"-16UNC	6	
26	9388-024	Carriage Bolt 5/16"-18UNC x 3/4" G5	4	
27	9390-026	Capscrew 5/16-18UNC x 1/2" G5	2	
28	9390-055	Capscrew 3/8"-16UNC x 1" G5	2	
29	9392-180	Roll Pin 3/8" Dia. x 2"	1	
30	9398-012	Elastic Lock Nut 3/8"-16UNC	3	
31	9405-074	Flat Washer 3/8" SAE	2	
32	9502361	Tarp 58 9/16" x 53"	1	
	9005581	Tarp Patch Kit	-	
33	97189	Hex Nut/Large Flange 1/4"-20UNC	4	
34	9807	Lock Nut/Top 5/16"-18UNC	8	
35	9928	Lock Nut/Top 3/8"-16UNC	12	

## Cover Crop Seeder — Parts

### Frame Brace Kit

Please visit [www.unverferth.com/parts/](http://www.unverferth.com/parts/) for the most current parts listing.

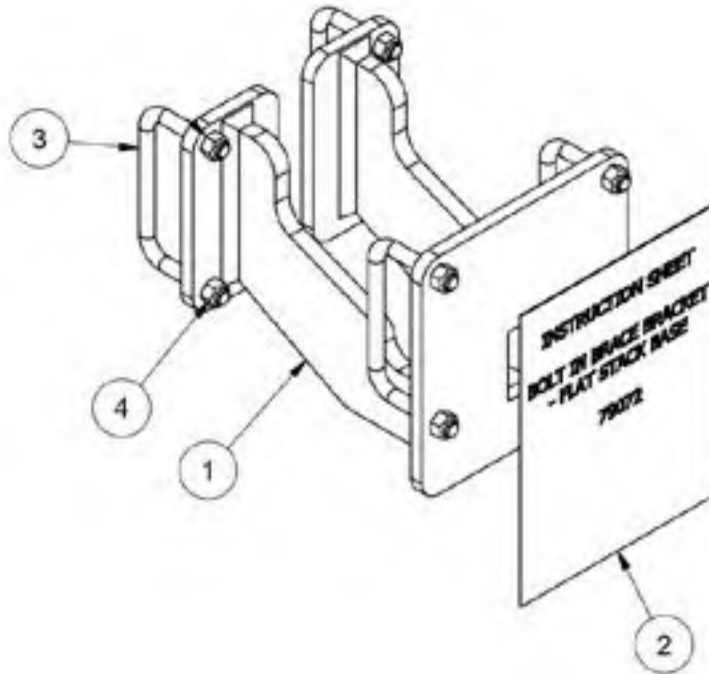

ITEM	PART NO.	DESCRIPTION	QTY	NOTES
	79069B	Bolt-In Brace Bracket Assembly	-	Includes Items 1-4
1	79064G	Frame Brace Weldment =Green=	1	Green Kit Only
	79064R	Frame Brace Weldment =Red=		Red Kit Only
2	79072	Instruction Sheet	1	
3	96874	U-Bolt 1/2"-13UNC x 3 1/8", 5 9/16" C/C	4	
4	9800	Lock Nut/Top 1/2"-13UNC	8	



# Cover Crop Seeder — Parts

## Rolling Harrow Bolt Kit

Please visit [www.unverferth.com/parts/](http://www.unverferth.com/parts/) for the most current parts listing.

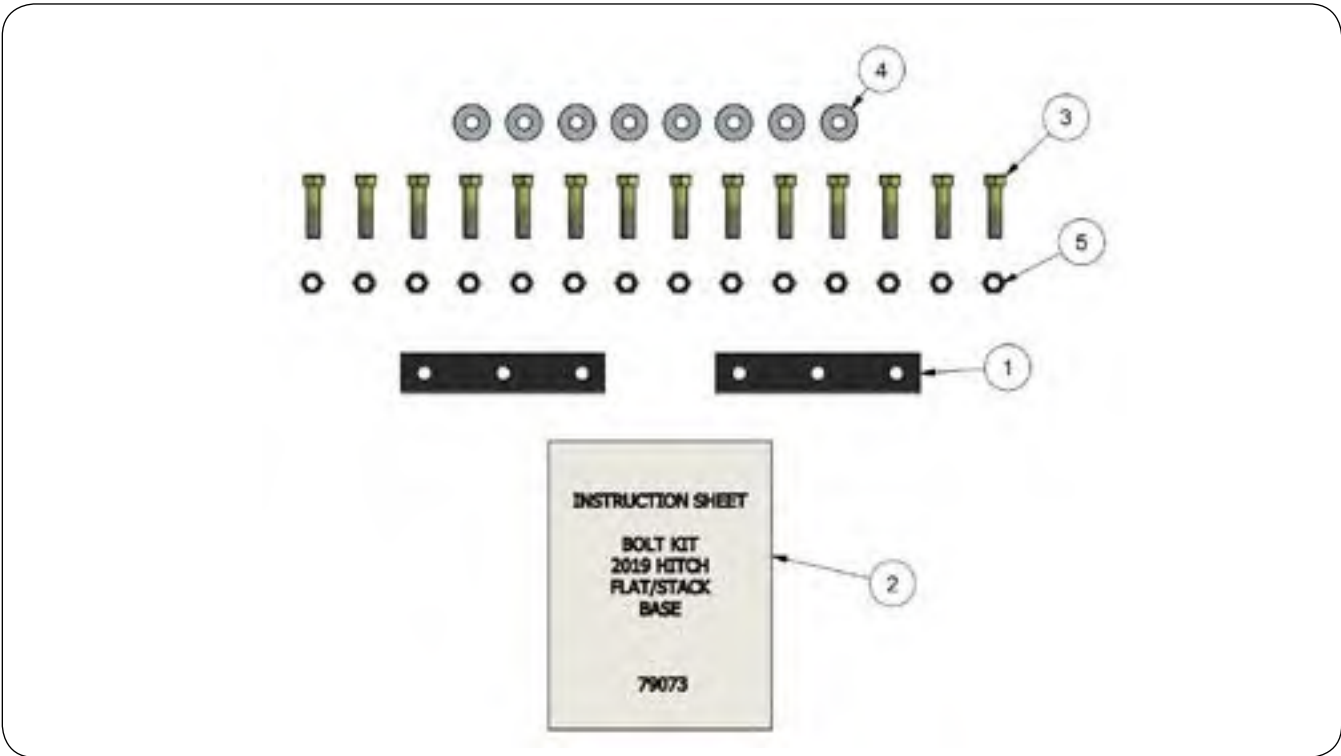

ITEM	PART NO.	DESCRIPTION	QTY	NOTES
	79209B	Bolt Kit For 2019 Hitch Flat/Stack Base	-	Serial Number A64740100 & Up Includes Items 1-5
1	78945B	Backer Plate	2	
2	79073	Instruction Sheet	1	
3	91299-103	Capscrew, 1/2"-13UNC x 2" G8	14	
4	9503326	Flat Washer 1/2"	8	
5	9800	Lock Nut/Top 1/2"-13UNC	14	



***Unverferth***  
***Manufacturing Company, Inc.***

[www.unverferth.com](http://www.unverferth.com)